

UPQ-D3 Wide Coverage Loudspeaker

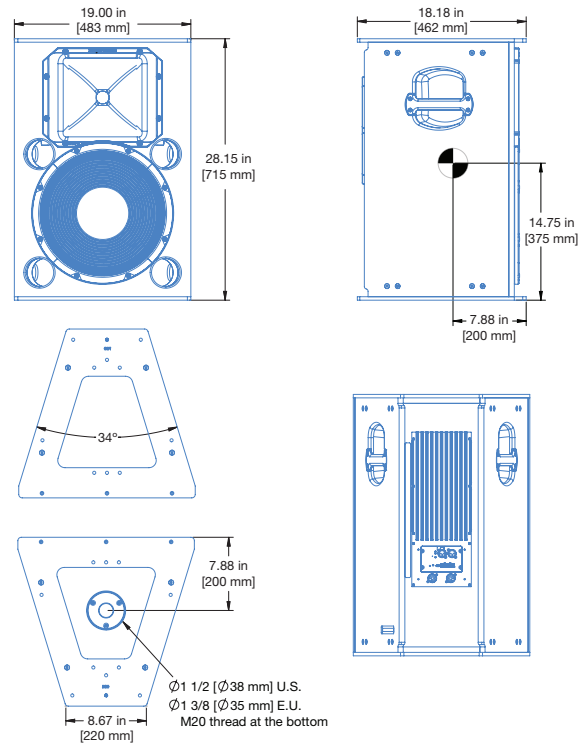
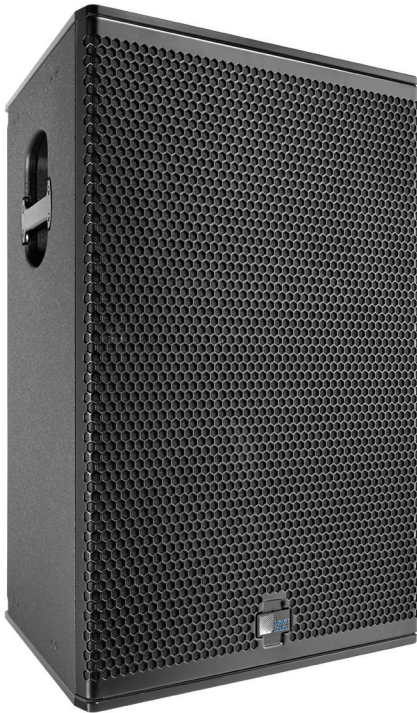

Meyer Sound’s UPQ-D3 wide coverage loudspeaker evolves from the UPQ-1P and UPQ-2P product line, now optimized using the advanced technology that made the LEO® family an award-winning product line. UPQ-D3 features:

- Wider vertical coverage, constant-Q horn with -6 dB points at 80° x 80° (-10 dB points at 100° x 100°)
- An innovative, newly designed, highly efficient Class D amplifier with reduced current draw that reproduces any sound with linearity over a wide dynamic range
- Optimized frequency and phase response characteristics
- Lightened cabinet weight of 95 lbs (43 kgs)
- Redesigned cabinet that retains the original size, grille frame, and rigging options of previous UPQ products

UPQ-D3 continues to offer an extremely consistent polar response and a gentle coverage rolloff that extends uniformly out to its -10 dB points of 100° by 100°. The horn’s smooth and consistent performance is the result of meticulous research in Meyer Sound’s anechoic chamber, and it exhibits a remarkably consistent beamwidth in both the horizontal and vertical planes. In addition, the UPQ-D3 horn delivers uniform attenuation for all frequencies outside the specified beamwidth.

In addition to the Constant-Q horn, the loudspeaker features a low frequency 15 in neodymium magnet cone driver and 4 in diaphragm compression driver, both designed and manufactured at Meyer Sound’s Berkeley, California headquarters. Suitable for use in a range of sound reinforcement applications, the UPQ-D3 works well as a front-of-house main loudspeaker in small to

mid-sized venues, or as a fill loudspeaker in larger systems.

The proprietary two-channel, class D power amplifier yields a total power output of 1800 W. Audio input routes through electronic crossover and correction filters, as well as through driver-protection circuitry. Phase-corrected processing ensures a flat acoustical amplitude and phase response, resulting in an exceptional impulse response and precise imaging.

Each amplifier channel has sophisticated limiters that are easily monitored with the limit LEDs on the unit’s rear panel. The UPQ-D3’s modular amplifier and processing electronics incorporate Meyer Sound’s Intelligent AC™ power supply, which adapts to any power voltage worldwide and provides soft-turn on and transient protection. The UPQ-D3 uses a XLR 3-pin female input with male loop output connector.

The optional RMS™ remote monitoring system module provides comprehensive monitoring of loudspeaker parameters from a host computer running Compass® software. An optional XLR 5-pin connector is available to accommodate both balanced audio and RMS signals.

The UPQ-D3 provides extremely high power output with low distortion in a vented two-way enclosure. The UPQ-D3’s durable trapezoidal enclosure has a slightly textured black finish, an integral stand mount receptacle, and versatile rigging end plates. Made of heavy-duty, high-strength, corrosion-resistant 6061-T6 aluminum, the endplates incorporate threaded M10 attachment points.

QuickFly® rigging options include the MPA-UPQ pick-up and array plate and MYA-UPQ mounting yoke. Other options include Meyer Sound weather protection and custom color finishes for specific cosmetic requirements.

## FEATURES AND BENEFITS

- Wide, symmetrical pattern covers broad listening areas
- Highly energy efficient amplifier with sophisticated digital signal processing that provides extraordinarily flat amplitude and phase response for tonal accuracy and precise imaging
- Integral stand mount and quick and easy QuickFly mounting options facilitates rigging

## APPLICATIONS

- Theatrical sound reinforcement
- Houses of worship
- Portable and installed audio-visual systems
- Nightclubs

## PRELIMINARY SPECIFICATIONS

ACOUSTICAL	
Operating Frequency Range	53 Hz - 19 kHz
Frequency Response	56 Hz - 18 kHz $\pm$ 4 dB
Phase Response	80 Hz - 18 kHz $\pm$ 45°
Linear Peak SPL <sup>1</sup>	<b>133 dB (M-noise)</b> , 130.5 dB (Pink noise), 133.5 dB (B-noise)
COVERAGE	
	80° x 80° (-6 dB) 100° x 100° (-10 dB)
TRANSDUCERS	
Low Frequency	One high-power 15 in cone driver with neodymium magnet; 2 $\Omega$ nominal impedance
High Frequency	One 4 in diaphragm compression driver; 8 $\Omega$ nominal impedance
AUDIO INPUT	
Connectors	XLR 3-pin female input with male loop output; optional XLR 5-pin connector to accommodate both balanced audio and RMS signals
Input Level	Audio source must be capable of producing +20 dBV (10 V rms) into 600 $\Omega$ to produce the maximum peak SPL over the operating bandwidth of the loudspeaker
AMPLIFIER	
Type	2-channel, Class-D
Total Output Power	1800 W peak
AC POWER	
Connectors	powerCON 20 input with loop output
Safety Rated Voltage Range	100–240 V AC, 50–60 Hz
CURRENT DRAW	
Maximum Long-Term Continuous Current (>10 sec)	2.8 A rms (115 V AC); 1.4 A rms (230 V AC); 3.2 A rms (100 V AC)
PHYSICAL	
Dimensions	W: 19.00 in (483 mm) x H: 28.15 in (715 mm) x D: 18.18 in (462 mm)
Weight	95 lb (43 kg)
Enclosure	Premium multi-ply birch with slightly textured black finish
Protective Grille	Powder-coated, hex-stamped steel with acoustical black mesh

1. **Linear Peak SPL** is measured in free-field at 4 m referred to 1 m. Loudspeaker SPL compression measured with M-noise at the onset of limiting, 2-hour duration, and 50-degree C ambient temperature is < 2 dB.

**M-noise** is a full bandwidth (10Hz–22.5 kHz) test signal developed by Meyer Sound to better measure a loudspeaker's music performance. It has a constant instantaneous peak level in octave bands, a crest factor that increases with frequency, and a full bandwidth Peak to RMS ratio of 18 dB.

**Pink noise** is a full bandwidth test signal with Peak to RMS ratio of 12.5 dB. **B-noise** is a Meyer Sound test signal used to ensure measurements reflect system behavior when reproducing the most common input spectrum, and to verify there is still headroom over pink noise.