

ULTRA-X20XP™ Compact Wide Coverage Loudspeaker
ULTRA-X22XP™ Compact Narrow Coverage Loudspeaker
ULTRA-X23XP™ Compact Broad Coverage Loudspeaker

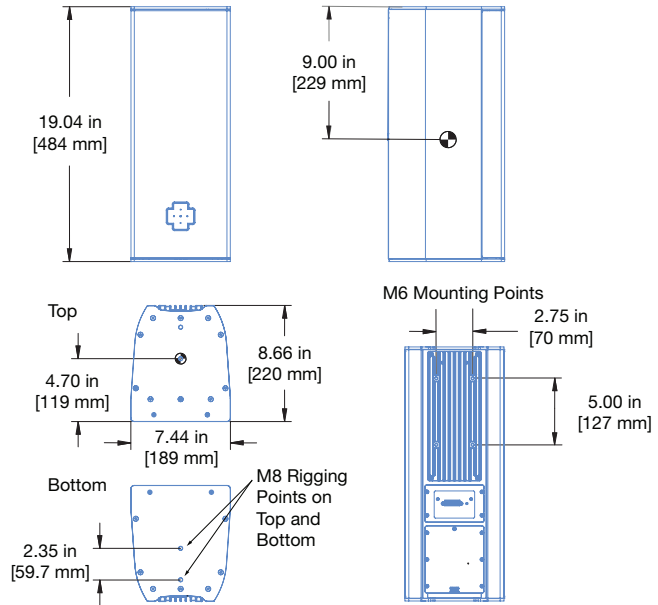
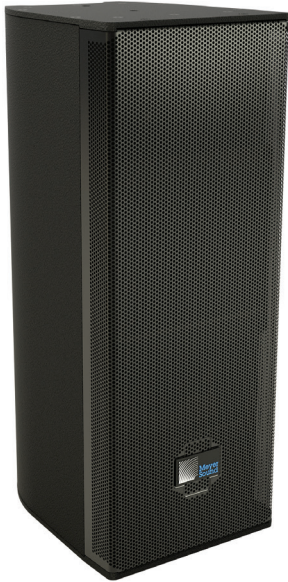

Meyer Sound's ULTRA-X20XP loudspeaker extends the award-winning, state-of-the-art ULTRA-X40 point source technology to a smaller version for size- and weight-critical applications. Enhancements extending to the smaller ULTRA-X20XP/22XP/23XP versions include:

- An innovative, highly efficient class-D amplifier that reproduces any sound source with linearity over a wide dynamic range.
- A weight of only 27 lb (12.3 kg) and a reduced cabinet size.
- A concentric driver configuration that has all the benefits of a coaxial driver, yet none of the disadvantages. This configuration also supports directional control of frequencies down to 600 Hz.
- A rotatable, extremely well-behaved horn designed for very precise, even coverage. This horn design, in conjunction with the concentric driver configuration, delivers the same pattern regardless of orientation.

The ULTRA-X20XP loudspeaker provides high power output, low distortion, and consistent polar response in a very compact, vented enclosure. The loudspeaker features two 5-inch cone low-frequency drivers and one 2-inch diaphragm compression driver coupled with a rotatable 110° x 50° Constant-Q horn. A more controlled pattern is available on the ULTRA-X22XP model, which is fitted with a rotatable 80° x 50° Constant-Q horn. A wider coverage version, the ULTRA-X23XP, offers a 110° x 110° Constant-Q horn.

Because of its proprietary, high-frequency horn, the beamwidth remains consistent within close tolerances in both the horizontal and vertical planes, and across the horn's operating frequency range. Uniformly predictable polar behavior takes much of the guesswork out of system design and assures optimal system performance.

A three-channel, class-D digital power amplifier powers the ULTRA-X20XP loudspeaker, which has a total peak power output of 860 watts. Audio processing includes electronic crossover, correction filters for phase and frequency response, and driver protection circuitry. Phase-corrected

electronics ensure flat acoustical amplitude and phase response, resulting in exceptional impulse response and precise imaging.

With IntelligentDC technology, the ULTRA-X20XP receives DC power and balanced audio from a single Phoenix™ 5-pin connector. Powering the loudspeakers from a Meyer Sound MPS IntelligentDC external power supply eliminates the need for wiring conduits while still preserving the advantages of self-powered systems.

The Meyer Sound MPS IntelligentDC power supplies distribute DC power and balanced audio to ULTRA-X20XP loudspeakers or other Meyer Sound IntelligentDC loudspeakers. The ULTRA-X20XP's amplifier and signal-processing circuits store DC power and tolerate voltage drops, thereby accommodating light-gauge cables and lengthy cable runs. Composite multi-conductor cables, such as Belden® 1502 or equivalent, can deliver both DC power and balanced audio to loudspeakers at cable lengths up to 150 feet with just 1 dB of loss in peak SPL using 18 AWG wire for power. Longer cable lengths are possible with heavier gauge wires. The two-channel MPS-482HP power supply is ideal for applications requiring a small channel count or the capability for mounting the supply remotely on a wall or ceiling, while the 8-channel MPS-488HP is suitable for larger installations. The MPS-488HP can be optionally purchased with an RMS module for connecting to Meyer Sound's remote monitoring system.

Meyer Sound builds the elegant, slightly curved enclosure out of aluminum with a slightly textured black finish. A powder-coated, round-perforated steel grille provides protection to the front of the loudspeaker.

The ULTRA-X20XP includes two integral M8 rigging points on each end to enable a variety of configurations including those requiring pole mounting, hanging individually from a single point, wall mounting or ceiling mounting. The ULTRA-X20XP also includes four M6 threaded holes with a 5-inch by 2.75-inch (127 mm by 70 mm) hole pattern on the rear for use with third-party wall mounts. Optional rigging accessories include a 35 mm to M8 pole adapter, a U-bracket, a yoke, and a pinnable link on a channel that allows the hanging of one or two units from a single pick-up point. Other options include weather protection and custom color finishes.

FEATURES AND BENEFITS

- A compact, elegant and light aluminum enclosure encases exceptional fidelity and surprising power capability
- Extraordinarily flat amplitude and phase response ensures tonal accuracy and precise imaging
- Wide pattern covers broad listening areas
- Rotatable horn provides installation flexibility
- Integral stand mount and QuickFly® mounting options facilitate rigging

APPLICATIONS

- Multi-purpose Audio/Visual
- Corporate rental
- Houses of worship
- Conference rooms
- High-end private installations
- Retail spaces
- Theater

ACCESSORIES AND ASSOCIATED PRODUCTS

MYA-X20 Yoke Kit (PN 40.297.450.01): The MYA-X20 Yoke suspends a single ULTRA-X20XP/22XP/23XP loudspeaker and supports a wide range of horizontal and vertical adjustments. The yoke attaches to the top and bottom of the loudspeaker using two included M8 bolts/washers. The kit also includes two M8 knobs/washers. The yoke may also be mounted on a 35 mm pole to facilitate easy panning and tilting by using the optional PAS-M8 Adapter Sleeve.

MTC-X20 Top Channel Kit (PN 40.297.430.01): The MTC-X20 Top Channel kit includes a pinnable link in a channel that mounts directly to the top of the ULTRA-X20XP/22XP/23XP rig nuts and supports pick-up of up to two ULTRA-X20XP/22XP/23XP loudspeakers from a single point using the two included lock pins and 3/8-inch shackle. (Three MTC-X20 Top Channels needed to hang two speakers.) The kit includes two M8 socket head screws for attaching the channel to the loudspeaker.

PAS-M8 Adapter Sleeve M8 (35 MM Pole) (PN 40.010.975.01): The PAS-M8 Adapter Sleeve facilitates connecting a 35 mm pole to the ULTRA-X20XP M8 rig nuts on the top/bottom of the loudspeaker. It can also be used with the MYA-X20 to pole-mount the yoke (a nut and washer are required for this application).

MUB-X20 U-Bracket Kit (40.297.454.01): The MUB-X20 U-Bracket allows a single ULTRA-X20XP/22XP/23XP loudspeaker to be mounted to a wall (in either vertical or horizontal orientations), to the ceiling or onto the floor. The kit includes two M8 bolts/washers and two M8 knobs/washers.

MPK-POLE 35MM/M20 Adjustable Pole Kit (PN 40.010.973.01): Adjustable length 927–1524 mm (36.5–60 in) pole with assisted lift. Lower shaft fits 35 mm cups or use the removable M20 threaded lug for added stability in pole mount cups. Additional 35 mm to 38 mm (1.5 in) adapter included. Upper shaft includes **PAS-M8 Adapter Sleeve** to fit loudspeakers with M8 rig nuts onto a 35 mm speaker stand. The PAS-M20 and 750-LFC/900-LFC Subwoofer Internal Pole Mount Cup (35 mm/M20) are also included.

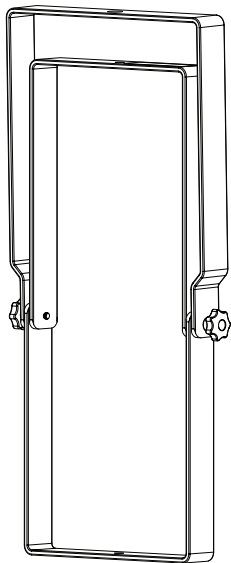

MYA-X20 Yoke
(PN 40.297.450.01)

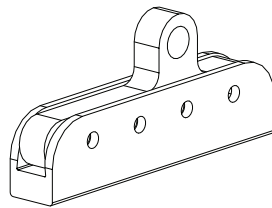

MTC-X20 Top Channel
(PN 40.297.430.01)

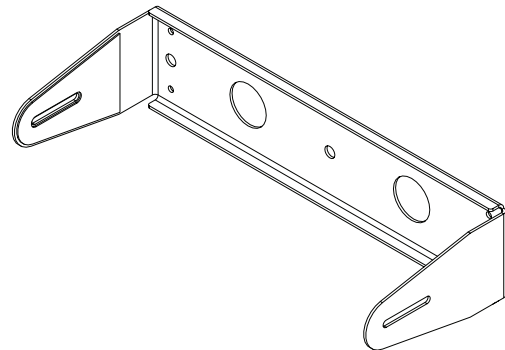

MUB-X20 U-Bracket (PN 40.297.454.01)

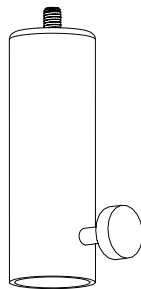

PAS-M8 Adapter Sleeve
M8 (35 MM Pole)
(PN 40.010.975.01)

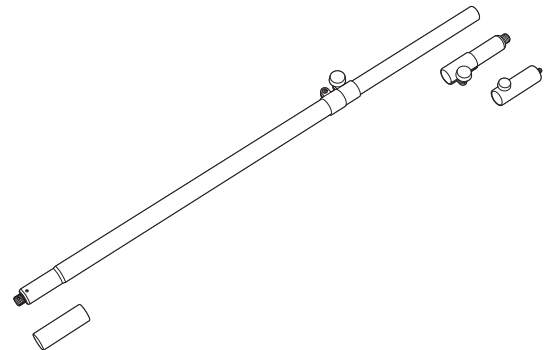

MPK-POLE Pole Kit (PN 40.010.973.01)

SPECIFICATIONS

ACOUSTICAL ¹	ULTRA-X20XP	ULTRA-X22XP	ULTRA-X23XP
Operating Frequency Range ²	60 Hz – 18 kHz	60 Hz – 18 kHz	60 Hz – 18 kHz
Frequency Response ³	65 Hz – 17.5 kHz ± 4 dB	65 Hz – 17.5 kHz ± 4 dB	65 Hz – 17.5 kHz ± 4 dB
Phase Response	95 Hz – 18 kHz ±45°	95 Hz – 18 kHz ±45°	95 Hz – 18 kHz ±45°
Linear Peak SPL ⁴	127 dB with 20 dB crest factor (M-noise), 123.5 dB (Pink Noise), 125.5 dB (B-noise)	128.5 dB with 20 dB crest factor (M-noise), 123.5 dB (Pink Noise), 125 dB (B-noise)	127.5 dB with 20 dB crest factor (M-noise), 124 dB (Pink Noise), 125.5 dB (B-noise)
COVERAGE			
	Rotatable horn: 110° x 50°	Rotatable horn: 80° x 50°	110° x 110°
TRANSDUCERS			
Low Frequency	Two 5-inch cone drivers; 6 Ω nominal impedance		
High Frequency	One 2-inch diaphragm compression driver connected to a rotatable horn; 8 Ω nominal impedance		
AUDIO INPUT			
Type	Differential, electronically balanced		
Maximum Common Mode Range	±15 V DC, clamped to earth for voltage transient protection		
Connector	Phoenix 5-pin male		
Input Impedance	10 kΩ differential between pins 2 and 3		
Wiring	Pin 1: DC Power (-) Pin 2: DC Power (+) Pin 3: Audio Shield, Chassis/earth through 1 kΩ, 1000 pF, 15 V clamp network to provide virtual ground lift at audio frequencies Pin 4: Audio (-) Pin 5: Audio (+)		
Nominal Input Sensitivity	0 dBV (1.0 V rms) continuous is typically the onset of limiting for noise and music		
Input Level	Audio source must be capable of producing of +20 dBV (10 V rms) into 600 Ω to produce the maximum peak SPL over the operating bandwidth of the loudspeaker.		
AMPLIFIER			
Type	Three-channel, Class-D		
Total Output Power ⁵	860 W peak		
THD, IM, TIM	<0.02%		
Cooling	Convection		
DC POWER			
Connector	Phoenix 5-pin male provides power and audio connection (see Wiring above)		
Safety Rated Voltage Range ⁶	48 V DC (Meyer Sound IntelligentDC External Power Supply Required)		
PHYSICAL			
Dimensions	W: 7.44 in (189 mm) x H: 19.04 in (484 mm) x D: 8.66 in (220 mm)		
Weight	27 lb (12.3 kg)		
Enclosure	Aluminum with slightly textured black finish		
Protective Grille	Powder-coated, round-perforated steel		
Rigging	Two integrated M8 threaded points on each end; optional accessories for various rigging options (see accessories section); four M6 threaded holes with 5-inch by 2.75-inch (127 mm by 70 mm) hole pattern on the rear for use with third-party wall mounts.		

SPECIFICATIONS, CONT'D.

NOTES

1. Loudspeaker system predictions for coverage and SPL are available in Meyer Sound's MAPP System Design Tool.
2. Recommended maximum operating frequency range. Response depends on loading conditions and room acoustics.
3. Free-field, measured with 1/3 octave frequency resolution at 4 m.
4. **Linear Peak SPL** is measured in free-field at 4 m referred to 1 m. Loudspeaker SPL compression measured with M-noise at the onset of limiting, 2-hour duration, and 50 °C ambient temperature is < 2 dB.
M-noise is a full bandwidth (10 Hz–22.5 kHz) test signal developed by Meyer Sound to better measure the loudspeaker's music performance. It has a constant instantaneous peak level in octave bands, a crest factor that increases with frequency, and a full bandwidth Peak to RMS ratio of 18 dB.
Pinknoise is a full bandwidth test signal with Peak to RMS ratio of 12.5 dB.
B-noise is a Meyer Sound test signal used to ensure measurements reflect system behavior when reproducing the most common input spectrum, and to verify there is still headroom over pink noise.
5. Peak power based on the maximum unclipped peak voltage the amplifier will produce into the nominal load impedance.
6. Tolerates voltage drops (due to long cable runs) up to 30%.

ARCHITECTURAL SPECIFICATIONS

The loudspeaker shall be a self-powered, full-range system. The transducers shall consist of two 5-inch cone drivers and one 2-inch diaphragm compression driver connected to horns with different coverage depending on the model: the wide coverage model shall have a 110° x 50° rotatable horn, the narrow coverage model shall have a 80° x 50° rotatable horn, and the broad coverage shall have a 110° x 110° horn.

The loudspeaker system shall incorporate internal processing electronics and a three-channel, class-D amplifier. Processing functions shall include equalization, phase correction, signal division and protection for the high and low-frequency sections. Peak output power shall be 860 W total with 8 Ω nominal impedance for the high-frequency channel and 6 Ω nominal impedance for the low-frequency channels. Distortion (THD, IM, TIM) shall not exceed 0.02%.

Performance specifications for a typical production unit shall be as follows: operating frequency range shall be 60 Hz – 18 kHz; phase response shall be 95 Hz – 18 kHz ±45°. Linear peak SPL for the wide coverage version shall be 127 dB with 20 dB crest factor, measured with M-noise, free-field at 4 m referred to 1 m, and its coverage pattern (–6 dB points) shall be 110° by 50°, horizontal or vertical dependent on horn orientation. Linear peak SPL for the narrow coverage version shall be 128.5 dB with 20 dB crest factor, measured with M-noise, free-field at 4 m referred to 1 m, and its coverage pattern (–6 dB points) shall be 80° by 50°, horizontal or vertical dependent on horn orientation. Linear peak SPL for the broad coverage

version shall be 127.5 dB with 20 dB crest factor, measured with M-noise, free-field at 4 m referred to 1 m, and its coverage pattern (–6 dB points) shall be 110° by 110°.

The audio input shall be electronically balanced with a 10 kΩ impedance and shall accept a nominal 0 dBV (1 V rms) signal. The connector shall be a Phoenix 5-pin male.

Power requirements for the loudspeaker shall be a Meyer Sound MPS IntelligentDC power supply capable of delivering 48 V DC. Meyer Sound's RMS remote monitoring system shall be optionally available via the MPS-488HP power supply.

All loudspeaker components shall be mounted in an acoustically vented enclosure constructed of aluminum with a slightly textured black finish with two integrated M8 threaded points on each end and four M6 threaded holes with a 5-inch by 2.75-inch (127 mm by 70 mm) hole pattern on the rear. The front protective grille shall be powder-coated, round-perforated steel. Dimensions shall be W: 7.44 in (189 mm) x H: 19.04 in (484 mm) x D: 8.66 in (220 mm).

Weight shall be 27 lb (12.3 kg).

The wide coverage loudspeaker model shall be the Meyer Sound ULTRA-X20XP, the narrow coverage loudspeaker model shall be the Meyer Sound ULTRA-X22XP, and the broad coverage loudspeaker model shall be the Meyer Sound ULTRA-X23XP.