



LYON™ : Linear Array Loudspeaker

The self-powered LYON linear line array loudspeaker is a member of Meyer Sound's LEO Family of linear loudspeakers, designed to reproduce audio faithfully with tremendous power and clarity, without coloring the sound, even when pushed to the limit. LYON delivers the same headroom and precision as the acclaimed LEO-M™ with the same cutting-edge technology housed in a lighter and more compact cabinet. Optimized rigging and self-powered configuration streamlines both setup and breakdown for LYON systems. LYON is ideal for medium- to large-scale array applications that do not require the extreme long-throw capability of LEO-M.

For greater flexibility, LYON is available in two models: LYON-M for primary array coverage and LYON-W for wide coverage. LYON-W can be used wherever wide coverage is needed in LYON arrays, at the bottom or in the middle of primary arrays, or even at the top of outfill arrays. Because LYON-W matches the acoustical characteristics and vertical coverage of LYON-M, transitions for horizontal coverage are seamless. Both LYON models are matched acoustically to LEO-M and can be used for downfill and midfill at the bottom of LEO-M arrays, and as supplemental sidefill and outfill arrays in LEO-M systems.

LYON arrays are ideally paired with Meyer Sound's 1100-LFC low-frequency control element for bass reproduction. Entire systems are driven by Meyer Sound's Galileo Callisto™ 616 array processor, which provides matrix routing, alignment, and processing for array components. To guarantee optimum system performance, including coverage patterns and maximum peak SPL, LYON systems should be designed with Meyer Sound's MAPP Online XT™ acoustical prediction software.

LYON's high-frequency section is comprised of two proprietary compression drivers coupled to a constant-directivity horn through a patented REM™ manifold. The manifold's smooth radiating characteristics afford tight vertical coverage. The low-frequency section includes two long-excursion cone drivers, also proprietary, capable of withstanding high, continuous output levels. Precise phase and magnitude alignment between low- and high-frequency drivers yields consistent and well-behaved system responses.

The unit's onboard power amplifier operates at nominal voltages from 85–134 V AC and 165–264 V AC at 50–60 Hz. TruPower® limiting ensures maximum driver protection, minimizing

power compression while yielding high constant output under high continuous and peak power conditions. The amplifier, control electronics, and power supply are contained in a single field-replaceable module located on the rear of the cabinet.

Meyer Sound's RMS™ remote monitoring system comes standard with all LYON loudspeakers and

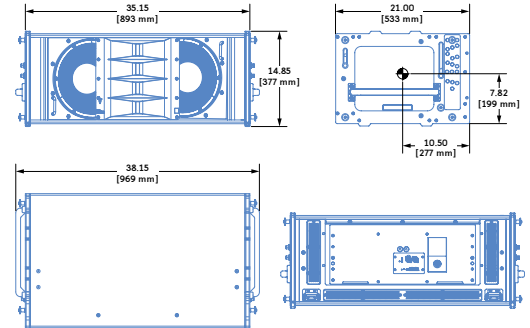

- Dimensions** 38.15" w x 14.85" h x 21.00" d (969 mm x 377 mm x 533 mm)
- Weight** 199 lbs (90.3 kg)
- Enclosure** Multi-ply hardwood
- Finish** Black textured
- Protective Grille** Hex-stamped steel with acoustical black mesh
- Rigging** Endframes with captive GuideALinks, quick-release pins, and detachable handles

provides comprehensive monitoring of system parameters on a Mac® or Windows®-based computer. Convenient XLR 5-pin connectors allow the use of composite cables carrying both RMS and balanced audio. XLR 3-pin audio connectors are also available.

LYON offers intuitive rigging with captive GuideALinks™ that can be set to the desired splay angles while cabinets rest in caster frames. The MTG-LYON top grid flies arrays of up to 18 LYONs at a 7:1 safety factor (with some restrictions). The optional MTF-LEO/LYON transition frame flies LYONs at the bottom of LEO-M arrays. Stacks of up to four LYON cabinets can be securely transported with the optional MCF-LYON caster frame; durable nylon covers, accommodating stacks of two, three, or four units, are available to protect the cabinets during transport.

The LYON cabinet is constructed of multi-ply hardwood and coated with a black-textured finish. A hex-stamped, steel grille with acoustical black mesh protects the unit's drivers. Other options include weather protection and custom color finishes for fixed installations and applications with specific cosmetic requirements.

FEATURES & BENEFITS

- Available in two models for greater flexibility: LYON-M for primary array coverage and LYON-W for wide coverage
- Integrates seamlessly with Meyer Sound's LEO-M and 1100-LFC
- High peak power output with exceptional linearity and transient reproduction at any operating level
- Self-powered for simplified setup and increased reliability

APPLICATIONS

- Medium- to large-scale applications
- Arenas, performing arts centers, theatres, churches, and other fixed installations
- Touring sound reinforcement
- Downfill, midfill, sidefill, and outfill for LEO-M systems

LYON SPECIFICATIONS

ACOUSTICAL	
Operating Frequency Range ¹	55 Hz – 16.5 kHz
Phase Response	80 Hz – 16 kHz ±30°
TRANSDUCERS	
Low Frequency	Two 12" long-excursion cone drivers
High Frequency ²	Two 3" compression drivers
AUDIO INPUT	
Type	Differential, electronically balanced
Maximum Common Mode Range	±15 V DC, clamped to earth for voltage transient protection
Connectors ³	XLR female input with XLR male loop output
Input Impedance	10 kΩ differential between pins 2 and 3
Wiring ⁴	Pin 1: Chassis/earth through 1 kΩ, 1000 pF, 15 V clamped network to provide virtual ground lift at audio frequencies Pin 2: Signal + Pin 3: Signal – Pin 4: RMS Pin 5: RMS Case: Earth ground and chassis
DC Blocking	Differential DC blocking up to the maximum common mode voltage
CMRR	>50 dB, typically 80 dB (50 Hz – 500 Hz)
RF Filter	Common mode: 425 kHz Differential mode: 142 kHz
TIM Filter	Integral to signal processing (<80 kHz)
Nominal Input Sensitivity	0 dBV (1.0 V rms) continuous is typically the onset of limiting for noise and music
Input Level	Audio source must be capable of producing of +20 dBV (10 V rms, 14 V peak) into 600 Ω to produce the maximum peak SPL over the operating bandwidth of the loudspeaker
AMPLIFIER	
Type	3-channel complementary MOSFET output stages (class AB/H bridged)
Cooling	Two ultrahigh-speed primary fans, two ultrahigh-speed reserve fans
AC POWER	
Connectors	powerCON 32
Automatic Voltage Selection ⁵	95–125 V AC, 50–60 Hz; 208–235 V AC, 50–60 Hz
Operational Voltage Range	Turn-on: 85 V AC; Turn-off: 134 V AC Turn-on: 165 V AC; Turn-off: 264 V AC
Current Draw: Idle Current	0.6 A rms (230 V AC) 0.7 A rms (208 V AC) 1.2 A rms (115 V AC)
Maximum Long-Term Continuous Current (>10 sec)	5.6 A rms (230 V AC) 6.2 A rms (208 V AC) 11.2 A rms (115 V AC)
Burst Current (<1 sec) ⁶	7.5 A rms (230 V AC) 8.2 A rms (208 V AC) 15.4 A rms (115 V AC)
Maximum Instantaneous Peak Current	23 A peak (230 V AC) 25 A peak (208 V AC) 45 A peak (115 V AC)
Inrush Current	<15 A peak (230 V AC) <15 A peak (208 V AC) <15 A peak (115 V AC)
RMS NETWORK	
Equipped with 2-conductor, twisted-pair network, reporting all amplifier operating parameters to host computer	

NOTES:

1. Recommended maximum operating frequency range. Response depends on loading conditions and room acoustics.
2. High-frequency drivers coupled to a constant-directivity horn through a patented REM manifold.
3. Audio connectors available as XLR 5-pin or XLR 3-pin connectors. XLR 5-pin connectors accommodate both balanced audio and RMS signals.
4. Pins 4 and 5 for RMS only included with XLR 5-pin connectors.
5. Indicates the safety agency rated operational voltage range.
6. AC power cabling must be of sufficient gauge so that under burst current rms conditions, cable transmission losses do not cause the loudspeaker's voltage to drop below the specified operating range.



LYON — 04.232.004.02 A

Copyright © 2014
Meyer Sound Laboratories Inc.
All rights reserved

MEYER SOUND LABORATORIES INC.
2832 San Pablo Avenue
Berkeley, CA 94702

T: +1 510 486.1166
F: +1 510 486.8356

techsupport@meyersound.com
www.meyersound.com

ARCHITECT SPECIFICATIONS

The loudspeaker shall be a self-powered, linear, low-distortion, line array loudspeaker. Its transducers shall include two 3-inch compression drivers coupled to a constant-directivity horn through a patented REM manifold, and two 12-inch long-excursion cone drivers.

The loudspeaker shall incorporate internal processing and a 3-channel class AB/H bridged amplifier with complementary MOSFET output stages. Protection circuits shall include TruPower limiting. The audio input shall be electronically balanced with a 10 kΩ impedance and accept a nominal 0 dBV (1.0 V rms) signal (+20 dBV to produce maximum SPL). Audio connectors shall be XLR 3-pin, female and male,

accommodating balanced audio, or XLR 5-pin, accommodating both balanced audio and RMS. RF filtering shall be provided, and CMRR shall be greater than 50 dB (50 Hz – 500 Hz).

Performance specifications for a typical production unit shall be as follows, measured at 1/3-octave resolution: operating frequency range, 55 Hz to 16.5 kHz; phase response, 80 Hz to 16 kHz ±30 degrees.

The internal power supply shall perform EMI filtering, soft current turn-on, and surge suppression. Power requirements shall be nominal 100, 110, or 230 V AC line current at 50–60 Hz. UL and CE operating voltage ranges shall be 95–125 V AC and 208–235 V AC at

50–60 Hz. Current draw during burst shall be 7.5 A rms at 230 V AC and 15.4 A rms at 115 V AC. Current inrush during soft turn-on shall not exceed 15 A at 230 V AC. The AC power connector shall be a powerCON 32. The loudspeaker shall include an RMS remote monitoring system module.

Components shall be mounted in an optimally tuned, vented enclosure constructed of multi-ply hardwood and coated with a black-textured finish. Dimensions shall be 38.15" wide x 14.85" high x 21.00" deep (969 mm x 377 mm x 533 mm). Weight shall be 199 lbs (90.3 kg).

The loudspeaker shall be the Meyer Sound LYON.