

## 2100-LFC Low Frequency Control Element



*Keep these important operating instructions.  
Check [meyersound.com](http://meyersound.com) for updates.*

---

© 2023 Meyer Sound Laboratories, Incorporated  
2100-LFC Operating Instructions, PN 05.328.005.01 A2 2309

The contents of this manual are furnished for informational purposes only, are subject to change without notice, and should not be construed as a commitment by Meyer Sound Laboratories, Incorporated. Meyer Sound assumes no responsibility or liability for any errors or inaccuracies that may appear in this manual. Except as permitted by applicable copyright law, no part of this publication may be reproduced, stored in a retrieval system, or transmitted, in any form or by any means, electronic, mechanical, recording or otherwise, without prior written permission from Meyer Sound.

MEYER SOUND and the Meyer Sound wave logo are trademarks of Meyer Sound Laboratories, Incorporated and are registered in the United States Patent and Trademark Office, as well as in other countries.









The following is a partial list of additional Meyer Sound trademarks and service marks: 650-P®, 650-R2®, 750-LFC, 900-LFC, 1100-LFC, Acheron®, Acheron® 80, Acheron® 100, Acheron® Designer, Acheron® LF, Acheron® Studio, AlignALink, Amie®, Amie®-Sub, B-Noise, Bluehorn® System, BroadbandQ®, CAL®, CAL® 32, CAL® 64, CAL® 96, Callisto®, Compass®, Compass® Go by Meyer Sound, Compass® RMS, Composite EQ, Constellation®, CueConsole, CueStation, D-Mitri®, EXP®, Galileo®, Galileo® GALAXY 408, Galileo® GALAXY 816, Galileo® GALAXY 816-AES3, GuideALink, HMS-5, HMS-10, HMS-12, HMS-15, Intelligent AC, IntelligentDC, JM-1P, LCS, LEO®, LEO® Family, LEO®-M, LEOPARD®, LEOPARD®-M80, Libra®, LINA®, LYON®, LYON®-M, LYON®-W, LYON®-WXT, M Series, M'elodie®, M1D, M2D, M3D, MAPP, MAPP 3D, MAPP Online Pro®, MAPP XT, Matrix3, MatrixLink, MDM-832, MDM-5000, MICA®, MILO®, MINA, MJF-208, MJF-210, MJF-212A, MM-4XP, MM-4XPD, MM-10, MM-10ACX, MM-10XP, MPS-482HP, MPS-488X, MSL-4®, MultiSense, QuickFly®, QuietCool, REM®, RMS, RMServer, SB-2, SB-3F, SIM®, SIM® 3, Spacemap®, Spacemap® Go, SpeakerSense, Stella, Thinking Sound®, TM Array, TruPower®, TruShaping®, U-Shaping®, ULTRA-X20, ULTRA-X22, ULTRA-X23, ULTRA-X40, ULTRA-X42, UltraSeries, UMS-1P, UMS-1XP, UP-4slim, UP-4XP, UPJ-1P, UPJ-1XP, UPJunior, UPJunior-XP, UPM-1P, UPM-1XP, UPM-2P, UPM-2XP, UPQ-D1, UPQ-D2, UPQ-D3, USW-112P, USW-112XP, USW-210P, VariO, VLFC, VRAS, Wild Tracks, X-400C, X-800C.

All third-party trademarks mentioned herein are the property of their respective trademark holders.

# SAFETY INSTRUCTIONS

## SYMBOLS USED

These symbols indicate important safety or operating features in this booklet and on the frame or chassis:

							
Dangerous voltages: risk of electric shock	Important operating instructions	Protective earth ground	Hot surface: do not touch	Electronic instructions for use: instruction location in QR code 	AC Power Inlet	Milan Audio Port	Analog Audio Input Analog Audio Looping Output

## IMPORTANT SAFETY INSTRUCTIONS

- Read these instructions.
- Keep these instructions.
- Heed all warnings.
- Follow all instructions.
- Do not use this apparatus near water.
- Clean only with dry cloth.
- Do not block any ventilation openings. Install in accordance with Meyer Sound's installation instructions.
- Do not install near any heat sources such as radiators, heat registers, stoves, or other apparatus that produce heat.
- Do not defeat the safety purpose of the grounding-type plug. A grounding type plug has two blades and a third grounding prong. The third prong is provided for your safety. If the provided plug does not fit into your outlet, consult an electrician for replacement of the obsolete outlet.
- Connect the apparatus to a two-pole, three-wire grounding mains receptacle. The receptacle must be connected to a fuse or circuit breaker. Connection to any other type of receptacle poses a shock hazard and may violate local electrical codes.
- To reduce the risk of electric shock, disconnect the apparatus from the AC mains before installing audio cable. Reconnect the power cord only after making all signal connections.
- Protect the power cord from being walked on or pinched, particularly at plugs, convenience receptacles, and the point where they exit from the apparatus. The AC mains plug or appliance coupler shall remain readily accessible for operation.
- Only use attachments/accessories specified by Meyer Sound. Use only with the caster rails or rigging specified by Meyer Sound, or sold with the apparatus. Handles are for carrying only.
- Unplug this apparatus during lightning storms or when unused for long periods of time.
- This apparatus contains potentially dangerous voltages. Do not try to disassemble the apparatus. If equipped with an external fuse holder, the replaceable fuse is the only user-serviceable item. When replacing the fuse, only use the same type and the same value.
- Refer all other servicing to qualified service personnel. Servicing is required when the apparatus has been damaged in any way, such as when the power-supply cord or plug has been damaged; liquid has been spilled or objects have fallen into the apparatus; rain or moisture has entered the apparatus; the apparatus has been dropped; or when for undetermined reasons the apparatus does not operate normally.



**WARNING:** For Meyer Sound IntelligentDC Power Supply models MPS-488X, MPS-488HP, MPS-482HP, and the MM-10ACX loudspeaker the external wiring connected to the output terminals of the units require installation by an Instructed Person or the use of ready-made leads or cords.



**WARNING:** To reduce the risk of fire or electric shock, do not expose this apparatus to rain or moisture. Do not install the apparatus in wet or humid locations without using weather protection equipment from Meyer Sound.



**WARNING:** Class I apparatus shall be connected to a mains socket outlet with a protective earthing connection.











**CAUTION:** Disconnect the mains plug before disconnecting the power cord from the speaker.

# SAFETY INSTRUCTIONS

## SÍMBOLOS UTILIZADOS

Estos símbolos indican características importantes de seguridad u operación en este folleto y en el bastidor o chasis

							
Tensiones peligrosas: riesgo de descarga eléctrica	Instrucciones de funcionamiento importantes	Toma de tierra de protección	Superficie caliente: no tocar	Instrucciones de uso electrónicas: ubicación de instrucciones en el código QR 	Entrada de corriente alterna	Puerto de audio Milán	Entrada de audio analógico  Salida de bucle de audio analógico

## INSTRUCCIONES DE SEGURIDAD IMPORTANTES

- Lea estas instrucciones.
- Conserve estas instrucciones.
- Preste atención a todas las advertencias.
- Siga todas las instrucciones.
- No use este aparato cerca del agua.
- Limpiar solo con un paño seco.
- No bloquee las aberturas de ventilación. Instale de acuerdo con las instrucciones de instalación de Meyer Sound.
- No lo instale cerca de fuentes de calor como radiadores, rejillas de calefacción, estufas u otros aparatos que produzcan calor.
- No anule el propósito de seguridad del enchufe con conexión a tierra. Un enchufe con conexión a tierra tiene dos clavijas y una tercera clavija de conexión a tierra. La tercera clavija se proporciona para su seguridad. Si el enchufe provisto no encaja en su tomacorriente, consulte a un electricista para reemplazar el tomacorriente obsoleto.
- Para reducir el riesgo de descarga eléctrica, desconecte el aparato de la red eléctrica antes de instalar el cable de audio. Vuelva a conectar el cable de alimentación sólo después de realizar todas las conexiones de señal.
- Conecte el aparato a una toma de corriente de tres hilos y dos polos con conexión a tierra. El receptáculo debe estar conectado a un fusible o disyuntor. La conexión a cualquier otro tipo de receptáculo representa un riesgo de descarga eléctrica y puede violar los códigos eléctricos locales.
- Proteja el cable de alimentación para que no se pise ni se pellizque, especialmente en los enchufes, receptáculos de conveniencia y en el punto por donde sale del aparato. El enchufe de la red de CA o el acoplador del aparato deben permanecer fácilmente accesibles para su funcionamiento.
- Utilice únicamente los aditamentos / accesorios especificados por Meyer Sound. Úselo únicamente con los rieles de ruedas o los aparejos especificados por Meyer Sound, o vendidos con el aparato. Las asas son solo para transportar.
- Desenchufe este aparato durante tormentas eléctricas o cuando no se utilice durante períodos prolongados.
- Este aparato contiene tensiones potencialmente peligrosas. No intente desmontar el aparato. Si está equipado con un portafusibles externo, el fusible reemplazable es el único elemento que puede reparar el usuario. Cuando reemplace el fusible, use solo el mismo tipo y el mismo valor.
- Refiera todos los demás servicios a personal de servicio calificado. Se requiere servicio cuando el aparato se ha dañado de alguna manera, como cuando se ha dañado el cable de alimentación o el enchufe; se ha derramado líquido o han caído objetos dentro del aparato; lluvia o ha entrado humedad en el aparato; el aparato se ha caído; o cuando por razones indeterminadas el aparato no funciona con normalidad.



**ADVERTENCIA:** Para los modelos de fuente de alimentación IntelligentDC de Meyer Sound MPS-488X, MPS-488HP, and MPS-482HP, y el altavoz MM-10ACX, el cableado externo que se conecta a los terminales de salida de dichas unidades requiere ser instalado por una persona instruida o requiere el uso de cables prefabricados.



**ADVERTENCIA:** Para reducir el riesgo de incendio o descarga eléctrica, no exponga este aparato a la lluvia, o humedad. No instale el aparato en lugares mojados o húmedos sin usar equipo de protección contra la intemperie de Meyer Sound..



**ADVERTENCIA:** Los aparatos de Clase I se deben conectar a una toma de corriente con tierra física.











**PRECAUCIÓN:** Desconecte el enchufe de la red antes de desconectar el cable de alimentación del altavoz.

# SAFETY INSTRUCTIONS

## VERWENDETE SYMBOLE

Diese Symbole weisen auf wichtige Sicherheits- oder Betriebsmerkmale in dieser Broschüre und am Gehäuse bzw. Fahrgestell hin:

							
Gefährliche Spannungen: Stromschlaggefahr	Hinweis auf wichtige Punkte der Betriebsanleitung	Schutzerdung	Heiße Oberfläche: nicht berühren	Elektronische Gebrauchsanweisung: anweisungsort im QR-Code 	Wechselstromanschluss	Milan Audioanschluss	Analoger Audioeingang  Analoger Audio-Loop-Ausgang

## WICHTIGE SICHERHEITSANWEISUNGEN

- Lesen Sie diese Anleitung.
- Bewahren Sie diese Anleitung auf.
- Beachten Sie alle Warnungen.
- Befolgen Sie alle Anweisungen.
- Keine Verwendung in der Nähe von Wasser.
- Reinigung nur mit einem trockenen Tuch.
- Blockieren Sie keine Lüftungsöffnungen. Beachten Sie Meyer Sounds Installationsanweisungen.
- Installieren Sie das Gerät nicht in der Nähe von Wärmequellen wie Heizkörpern, Heizregistern, Öfen oder anderen Geräten, die Wärme erzeugen.
- Umgehen Sie nicht den Sicherheitszweck des Schutzkontaktsteckers. Ein geerdeter Stecker hat zwei Stifte und einen dritten Erdungskontakt. Der dritte Kontakt dient Ihrer Sicherheit. Wenn der mitgelieferte Stecker nicht in Ihre Steckdose passt, wenden Sie sich an einen Elektriker, um die veraltete Steckdose auszutauschen.
- Schließen Sie das Gerät nur an eine zweipolige, dreipolige geerdete Netzsteckdose, die mit einer Sicherung oder einem Schutzschalter verbunden ist, an. Der Anschluss an eine andere Art von Steckdose birgt die Gefahr eines Stromschlags und kann gegen die örtlichen Elektrovorschriften verstoßen.
- Zur Minimierung der Gefahr eines Stromschlages trennen Sie das Gerät vor dem Anschluss von Audio- und/oder Steuerleitungen vom Stromnetz. Das Netzkabel darf erst nach Herstellung aller Signalverbindungen wieder eingesteckt werden.
- Schützen Sie das Netzkabel vor Einklemmen und verwenden Sie einen Trittschutz, insbesondere an den Steckverbindungen und Anschlusspunkten. Diese müssen für den Betrieb leicht zugänglich bleiben.
- Verwenden Sie nur die von Meyer Sound spezifizierten Anbau- und Zubehörteile. Verwenden Sie nur die von Meyer Sound spezifizierten oder mit dem Gerät verkauften Transport- und Rigging-Elemente. Die Griffe sind ausschließlich zum Transport bzw. zum Tragen geeignet.
- Trennen Sie bei Gewitter oder bei längerer Nichtbenutzung des Gerätes die Netzverbindung.
- Dieses Gerät enthält potentiell gefährliche Spannungen. Versuchen Sie nicht, das Gerät zu zerlegen. Wenn das Gerät mit einer extern zugänglichen, austauschbaren Sicherung ausgestattet ist, ist diese das einzige Wartungselement für Nutzer. Verwenden Sie beim Tausch der Sicherungen ausschließlich die original Typen und Spezifikationen.
- Wenden Sie sich für alle anderen Wartungsarbeiten an qualifiziertes Servicepersonal. Eine Wartung ist erforderlich, wenn das Gerät in irgendeiner Weise beschädigt wurde, z. B. wenn das Netzkabel oder der Netzstecker beschädigt wurde, wenn Regen, Feuchtigkeit, Flüssigkeiten oder Gegenstände in das Gerät eingedrungen sind, wenn das Gerät heruntergefallen ist oder wenn das Gerät aus unbestimmten Gründen nicht normal funktioniert.



**WARNUNG:** Bei den Meyer Sound IntelligentDC Power Supply Modellen MPS-488X, MPS-488HP und MPS-482HP, sowie dem MM-10ACX Lautsprecher, muss die externe Verkabelung, die an die Ausgangsklemmen der Geräte angeschlossen wird, von einer geschulten Person installiert werden oder es müssen vorgefertigte Kabel oder Leitungen verwendet werden.



**WARNUNG:** Um das Risiko eines Brandes oder elektrischen Schlages zu verringern, setzen Sie das Gerät nicht Regen oder Feuchtigkeit aus. Installieren Sie das Gerät nicht an nassen oder feuchten Orten, ohne Wetterschutzelemente von Meyer Sound zu verwenden.



**WARNUNG:** Geräte der Klasse I müssen an eine Netzsteckdose mit Schutzerdung angeschlossen werden.











**ACHTUNG!** Ziehen Sie den Netzstecker, bevor Sie das Netzkabel vom Lautsprecher abziehen.

# SAFETY INSTRUCTIONS

## SYMBOLES UTILISÉS

Ces symboles indiquent les caractéristiques de sécurité ou de fonctionnement importantes dans ce livret et sur le cadre ou le châssis:

							
Pour indiquer les risques résultant de tensions dangereuses	Instructions d'utilisation importantes	Protection de terre	Surface chaude: ne pas toucher	Mode d'emploi électronique: emplacement des instructions dans le QR code 	Prise de courant alternatif	Port audio Milan	Entrée audio analogique Sortie de boucle audio analogique

## INSTRUCTIONS DE SÉCURITÉ IMPORTANTES

- Lisez ces consignes.
- Conservez ces consignes.
- Respecter toutes les mises en garde.
- Suivez toutes les consignes.
- Ne pas utiliser cet équipement à proximité d'un point d'eau.
- Nettoyer uniquement à l'aide d'un chiffon sec.
- Ne pas obstruer toute ouverture d'aération. Procéder à l'installation conformément aux instructions de Meyer Sound.
- Ne pas installer à proximité de sources de chaleur telles qu'un radiateur, une bouche d'air chaud, un poêle ou tout autre équipement qui dégage de la chaleur.
- Ne pas compromettre la sécurité de la prise de terre. Les prises comportent deux broches et une troisième broche de mise à la terre. La troisième broche est prévu pour votre sécurité. Si la fiche fournie ne rentre pas dans votre prise, consultez un électricien pour le remplacement de la prise obsolète.
- Branchez l'appareil sur une prise de courant bipolaire à trois fils avec mise à la terre. Le réceptacle doit être relié à un fusible ou à un disjoncteur. Le raccordement à tout autre type de prise présente un risque d'électrocution et peut enfreindre les codes électriques locaux.
- Pour réduire le risque d'électrocution, débranchez l'appareil du secteur avant d'installer le câble audio. Ne rebranchez le cordon d'alimentation qu'après avoir effectué toutes les connexions de signaux.
- Protéger le cordon d'alimentation contre les risques de piétinement ou de pincement, notamment au niveau des fiches, des prises de courant et du point de raccordement avec l'équipement. La prise secteur ou le coupleur de l'appareil doit rester facilement accessible pour le fonctionnement.
- N'utiliser que des fixations/accessoires spécifiés par Meyer Sound. Utiliser uniquement les accessoires de conditionnement ou d'accroches spécifiés par Meyer Sound, ou vendus avec l'appareil. Les poignées sont uniquement destinées au transport.
- Débrancher l'équipement pendant les orages ou s'il n'est pas utilisé pendant de longues périodes.
- Cet appareil contient des tensions potentiellement dangereuses. N'essayez pas de démonter l'appareil. Si l'appareil est équipé d'un porte-fusible externe, le fusible remplaçable est le seul élément réparable par l'utilisateur. Lorsque vous remplacez le fusible, utilisez uniquement le même type et la même valeur.
- Confier toutes les réparations et tâches d'entretien à un personnel qualifié. Une intervention est nécessaire si l'équipement a été abîmé, notamment en ce qui concerne le cordon ou la fiche d'alimentation électrique, en cas d'infiltration de liquide, de chute d'objets dans l'équipement, d'exposition de l'équipement à la pluie ou à l'humidité, de fonctionnement anormal ou de chute.



**AVERTISSEMENT :** Pour les modèles alimentés en Meyer Sound IntelligentDC par un MPS-488X, un MPS-488HP, un MPS-482HP ou un haut-parleur MM-10ACX, le câblage externe connecté aux bornes de sortie des unités nécessite une installation par une personne qualifiée ou l'utilisation de câbles ou cordons prêts à l'emploi.



**AVERTISSEMENT :** Pour réduire les risques d'incendie ou de décharge électrique, ne pas exposer cet équipement à la pluie ou à l'humidité. Ne pas installer l'appareil dans des endroits mouillés ou humides sans utiliser l'équipement de protection contre les intempéries de Meyer Sound.



**AVERTISSEMENT :** Les appareils de classe I doivent être connectés à une prise de courant avec une mise à la terre de protection.



**ATTENTION :** Débranchez la prise secteur avant de débrancher le cordon d'alimentation de l'enceinte

# SAFETY INSTRUCTIONS

## ИСПОЛЬЗУЕМЫЕ СИМВОЛЫ

Эти символы в данной брошюре и на оборудовании указывают на элементы и функции, влияющие на безопасность.

							
Опасное напряжение: риск поражения электрическим током	Важные инструкции по эксплуатации	Заземление	Горячая поверхность: не прикасайтесь	QR-код с ссылкой на инструкцию по эксплуатации 	Вход питания переменного тока	Аудиопорт MILAN	Аналоговый аудиовход  Аналоговый аудиовыход

## ВАЖНЫЕ ИНСТРУКЦИИ ПО ТЕХНИКЕ БЕЗОПАСНОСТИ

- Прочитайте эти инструкции.
- Храните эти инструкции.
- Прислушайтесь ко всем предупреждениям.
- Следуйте всем инструкциям.
- Не используйте устройство вблизи воды.
- Протирайте устройство только сухой тканью.
- Не блокируйте вентиляционные отверстия. Установите устройство в соответствии с инструкциями по установке Meyer Sound.
- Не устанавливайте устройство вблизи источников тепла, таких как радиаторы, обогреватели, печи или другие приборы, выделяющие тепло.
- Подключите устройство к двухполюсной трехпроводной сетевой розетке с заземлением. Розетка должна быть подключена к предохранителю или автоматическому выключателю. Подключение к розетке любого другого типа представляет опасность поражения электрическим током и может нарушать местные электротехнические нормы.
- Чтобы снизить риск поражения электрическим током, отключите устройство от сети переменного тока перед прокладкой аудиокабеля. Подключайте шнур питания только после выполнения всех прочих соединений.
- Не нарушайте сохранность штепсельной вилки заземляющего типа. Вилка заземляющего типа имеет два силовых контакта и третий заземляющий контакт, обеспечивающий безопасность. Если вилка не подходит к вашей розетке, обратитесь к электрику для замены устаревшей розетки.
- Не допускайте, чтобы по шнуру питания ходили или он был пережат, особенно в местах около выхода его из устройства и из электрической розетки. При этом шнур питания и розетка должны быть легко доступными при необходимости.
- Используйте только аксессуары, рекомендованные Meyer Sound. Используйте только элементы подвеса и крепления Meyer Sound или идущие в комплекте поставки. Ручки предназначены только для переноски.
- Отключайте устройство от сети во время грозы и в случаях, когда оно не используется в течение длительного времени.
- Этот аппарат находится под потенциально опасным напряжением. Не пытайтесь разбирать аппарат. Если устройство снабжено внешним предохранителем, производите его замену только на предохранитель с аналогичными параметрами, предназначенный для самостоятельной замены.
- Все остальное обслуживание должно выполняться квалифицированным персоналом. Обслуживание необходимо, когда само устройство или шнур, или вилка питания были повреждены, внутрь устройства попала влага или посторонние предметы, после падения или когда по неопределенным причинам устройство не работает нормально.



**ВНИМАНИЕ:** Внешняя проводка, подключенная к выходным клеммам блоков питания Meyer Sound IntelligentDC MPS-488X, MPS-488HP и MPS-482HP и динамиков MM-10ACX, должна выполняться квалифицированным специалистом или с использованием предварительно собранных кабелей.



**ПРЕДУПРЕЖДЕНИЕ:** Чтобы снизить риск возгорания или поражения электрическим током, не подвергайте устройство воздействию дождя или влаги. Не устанавливайте устройство в сырых или влажных местах без использования погодозащитного оборудования Meyer Sound.



**ПРЕДУПРЕЖДЕНИЕ:** Устройство класса I должны подключаться к сетевой розетке с защитным заземлением..



**ВНИМАНИЕ:** Перед отсоединением шнура питания от устройства отсоедините сетевую вилку от розетки.





# SAFETY INSTRUCTIONS

## 使用的符号

这些符号表示本手册中和车架或底盘上的重要安全或操作特征

							
危险的电压:有触电的危险	重要的操作说明	保护性接地	热表面:不要触摸	电子使用说明:二维码中的说明位置 	交流电源入口	米兰音频端口	模拟音频输入 模拟音频循环输出

## 重要安全说明

- 阅读这些说明。
  - 保存这些说明。
  - 听从所有警告。
  - 遵循所有的指示。
  - 不要在水边使用本设备。
  - 只能用干布清洁。
  - 不要堵塞任何通风口。按照Meyer Sound的安装说明进行安装。
  - 不要在任何热源附近安装,如散热器、热寄存器、炉子或其他产生热量的设备。
  - 不要破坏接地型插头的安全目的。接地型插头有两个插片和第三根接地线。提供第三根接地线是为了您的安全。如果提供的插头不适合您的插座,请咨询电工更换过时的插座。
  - 将设备连接到一个两极三线接地的电源插座上。该插座必须与熔断器或断路器相连。连接到任何其他类型的插座上都会有触电危险,并可能违反当地的电气法规。
  - 为了减少电击的危险,在安装音频线之前,请将设备与交流电源断开。只有在完成所有信号连接后才重新连接电源线。
  - 保护电源线不被踩踏或挤压,特别是在插头、便利插座以及它们从设备上退出的地方。交流电源插头和其他接口应保持随时可供操作。
  - 只能使用Meyer Sound指定的附件/配件。只能使用Meyer Sound指定的轮板车和吊挂件或者与设备一起出售的配件。握柄仅用于搬运。
  - 在雷雨天气或长时间不使用时,请拔掉本设备的插头。
  - 该设备包含潜在的危险电压。请勿尝试拆卸设备。如果配备了外部保险丝座,可更换的保险丝是用户唯一可维修的项目。更换保险丝时,只能使用相同类型和相同规格的保险丝。
  - 将所有其他维修工作交给合格的维修人员。当设备以任何方式损坏时,如电源线或插头损坏、液体洒出或物体落入设备、雨水或湿气进入设备、设备掉落、或由于无法确定的原因,设备不能正常运行时,需要进行维修。
-  **警告:** 对于 MEYER SOUND 智能直流电源型号 MPS-488X、MPS-488HP 和 MPS-482HP 以及 MM-10ACX 扬声器,连接到设备输出端子的外部接线需要由受过指导的人员安装或使用现成的导线或电线。
-  **警告:** 为减少火灾或电击的危险,请不要将本设备暴露在雨中或潮湿的环境中。如果没有使用 Meyer Sound 的防雨设备,请不要将设备安装在潮湿的地方。
-  **警告:** I类设备应连接到有保护性接地的电源插座上。
-  **注意事项:** 在断开扬声器的电源线之前,请先断开电源插头。



# SAFETY INSTRUCTIONS

## 사용된 기호

이 기호들은 이 책자와 프레임 또는 새시에 있는 중요한 안전설비 또는 작동 기능을 나타냅니다.

							
전기 위험: 감전 위험	중요 운영 지침	보호 접지	뜨거운 표면: 만지지 마세요	전자 설명서: QR 코드 의 지침 위치 	AC 전원 입구	밀라노 오디오 입력 포트	아날로그 오디오 오 입력  루프 아날로그 오디오 출력

## 중요 안전 지침

- 이 지침을 읽으십시오.
- 이 지침을 보관하십시오.
- 모든 경고에 유의하십시오.
- 모든 지침을 따르십시오.
- 물 근처에서 이 기기를 사용하지 마십시오.
- 마른 천으로만 청소하십시오.
- 환기구를 막지 마십시오. Meyer Sound의 설치 지침에 따라 설치하십시오.
- 라디에이터, 열 조절기, 스토브 또는 기타 열을 발생하는 장치와 같은 열원 근처에 설치하지 마십시오.
- 접지형 플러그의 안전 목적을 어기지 마십시오. 접지 유형 플러그에는 두 개의 날과 세 번째 접지 갈래가 있습니다. 세 번째 갈래는 귀하의 안전을 위해 제공됩니다. 제공된 플러그가 콘센트에 맞지 않으면 전기 기술자에게 오래된 콘센트를 교체하도록 문의하십시오.
- 장치를 2극, 3선 접지 전원 콘센트에 연결합니다. 콘센트는 퓨즈나 회로 차단기에 연결해야 합니다. 다른 유형의 콘센트에 연결하면 감전 위험이 있으며 지역 전기 규정을 위반할 수 있습니다.
- 감전의 위험을 줄이려면 오디오 케이블을 설치하기 전에 AC 주전원에서 장치를 분리하십시오. 모든 신호를 연결한 후에 만 전원 코드를 다시 연결하십시오.
- 전원 코드가 밟히거나 끼이지 않도록 특히 플러그, 콘센트, 기기에서 나오는 지점을 보호하십시오. AC 주전원 플러그 또는 기기 커플러는 작동을 위해 쉽게 접근할 수 있어야 합니다.
- Meyer Sound에서 지정한 부착물/액세서리만 사용하십시오. Meyer Sound에서 지정하거나 장치와 함께 판매되는 캐스터 레일 또는 장비만 사용하십시오. 손잡이는 운반용입니다.
- 번개가 칠 때나 장기간 사용하지 않을 때는 이 장치의 플러그를 뽑으십시오.
- 이 장치에는 잠재적으로 위험한 전압이 포함되어 있습니다. 기기를 분해하지 마십시오. 외부 퓨즈 홀더가 있는 경우 교체 가능한 퓨즈만 사용자가 수리할 수 있습니다. 퓨즈를 교체할 때는 같은 종류, 같은 값만 사용하십시오.
- 기타 모든 서비스는 자격을 갖춘 서비스 담당자에게 문의하십시오. 기술문의 서비스는 전원코드가 플러그가 손상된 경우, 액체를 쏟았거나 물체를 장치에 떨어뜨린 경우, 비 또는 습기가 장치에 들어간 경우, 장치를 떨어뜨린 경우 또는 알 수 없는 이유로 기기가 정상적으로 작동하지 않을 경우 등과 같은 장치가 손상되었을 때 필요합니다.



**경고:** MEYER SOUND INTELLIGENT DC 전원 공급 장치 모델 MPS-488X, MPS-488HP, MPS-482HP 및 MM-10ACX 스피커의 경우 장치의 출력 단자에 연결된 외부 배선은 지시를 받은 사람이 설치하거나 기성품 리드 또는 코드를 사용해야 합니다.



**경고:** 화재나 감전의 위험을 줄이려면 이 장치를 비나 습기에 노출시키지 마십시오. Meyer Sound의 날씨 보호 장비를 사용하지 않고 습하거나 습한 장소에 장비를 설치하지 마십시오.



**경고:** 클래스 I 장치는 보호 접지 연결이 있는 주 소켓 콘센트에 연결해야 합니다.





**주의:** 스피커에서 전원 코드를 뽑기 전에 메인 플러그를 뽑으십시오.

# SAFETY INSTRUCTIONS

## 使用する記号

これらの記号は、本冊子およびフレームやシャーシに記載されている安全上または操作上の重要な特徴を示しています

							
危険な電圧 感電の危険性	重要な操作方法	保護接地	熱い表面 触れないでください	電子使用説明書: 指示場所はQRコードで 	交流電源インレット	ミラノオーディオポート	アナログオーディオ入力 アナログオーディオルーピング出力

## 重要な安全上の注意

- この説明書をお読みください
- この説明書を保管してください
- すべての警告に注意してください
- すべての指示に従ってください
- この機器を水の近くで使用しないでください
- 乾いた布で拭いてください
- 換気口を塞がないでください。Meyer Soundの設置方法にしたがって設置してください
- 暖房器具やストーブなど、熱を発するものの近くに設置しないでください
- 接地型プラグの安全性を損なわないでください。接地型プラグには、2つのブレードと3つ目の接地用ブロングがあります。この第3の突起は、安全のために設けられています。付属のプラグがお使いのコンセントに合わない場合は、電気店に相談してコンセントを交換してください
- 本機を2極3線式のアース付き電源コンセントに接続します。このレセプタクルは、ヒューズまたはサーキットブレーカーに接続する必要があります。それ以外のタイプのコンセントに接続すると、感電の危険があり、地域の電気規則に違反する可能性があります
- 感電の危険を避けるため、オーディオケーブルを取り付ける前に本機をAC電源から切り離してください。電源コードの再接続は、すべての信号の接続が終わってから行ってください
- 電源コードは、特にプラグやコンセント、機器から出ている部分で、歩いたり挟まれたりしないように保護してください。AC電源プラグや機器のカプラーは、操作できるようにしておく必要があります
- 本製品には、Meyer Soundが指定したキャストールやリギング、または本製品と一緒に販売されているアタッチメントやアクセサリのみを使用してください。取っ手は持ち運び専用です
- 雷雨時や長期間使用しない場合は、本機の電源プラグを抜いてください
- 危険な電圧が含まれています。分解しようとししないでください。外部ヒューズホルダーが装備されている場合、交換可能なヒューズは、ユーザーが修理できる唯一のアイテムです。ヒューズを交換するときは、同じタイプと同じ値のみを使用してください。
- その他のサービスについては、資格を持ったサービス担当者にご相談ください。電源コードやプラグが破損したとき、液体をこぼしたとき、本機の中に物を落としたとき、雨や湿気が入ったとき、本機を落としたときなど、何らかの理由で本機が正常に動作しなくなったときには、修理が必要です



警告 MEYER SOUND INTELLIGENTDC POWER SUPPLY モデルMPS-488X、MPS-488HP、MPS-482HPおよびMM-10ACXスピーカーのユニットの出力端子に接続される外部配線は、専門家による設置または既製のリード線やコードを使用する必要があります。



警告 火災や感電の危険を避けるため、本機を雨や湿気にさらさないでください。本機を雨や湿気の多い場所に設置する場合は、Meyer Soundの耐候性機器を使用してください



警告 クラスI機器は、保護接地接続された主電源ソケットに接続する必要があります



注意 電源コードをスピーカーから取り外す前に、主電源プラグを取り外してください

تشير هذه الرموز إلى ميزات أمان أو تشغيل مهمة في هذا الكتيب وعلى الإطار أو الهيكل

							
فولتية خطيرة: خطر حدوث صدمة كهربائية	تعليمات تشغيل مهمة	التأريض الواقي	سطح ساخن: لا تلمس	تعليمات إلكترونية للاستخدام: موقع المساعدة موجود في رمز الاستجابة السريعة	التيار المتردد لمداخل الطاقة	"منفذ الصوت" ميلان	إدخال الصوت التناظري إخراج الصوت التناظري
							

## تعليمات أمنية هامة

- افصل هذا الجهاز أثناء العواصف الرعدية أو عند عدم استخدامه لفترات طويلة من الزمن
- يحتوي هذا الجهاز على الفولتية التي من المحتمل أن تكون خطيرة. لا تحاول تفكيك الوحدة. إذا كان الجهاز مزوداً بحامل فيوز خارجي ، فإن المصهر القابل للاستبدال هو المكون الوحيد الذي يمكن للمستخدم صيانتته. عند استبدال المصهر ، استخدم فقط نفس النوع ونفس القيمة
- قم بإحالة جميع الخدمات الأخرى إلى موظفي الخدمة المؤهلين. يلزم إجراء الصيانة في حالة تعرض الجهاز للتلف بأي شكل من الأشكال ، كما هو الحال عند تلف سلك أو قابس الإمداد بالطاقة ؛ انسكاب سائل أو سقطت أشياء في الجهاز ؛ مطر أو دخلت الرطوبة إلى الجهاز ؛ تم إسقاط الجهاز ؛ أو عندما لا يعمل الجهاز بشكل طبيعي لأسباب غير محددة

بالنسبة لموديلات

Meyer Sound IntelligentDC Power Supply

و مكبر الصوت MPS-488HP و MPS-488HP و MPS-488X  
تتطلب الأسلاك الخارجية المتصلة بأطراف الإخراج ، MM-10ACX ،  
للوحدات المثبتة من قبل شخص موجه أو استخدام الخيوط أو  
الحوال جاهزة للاستعمال



تحذيرات لتقليل مخاطر نشوب حريق أو صدمة كهربائية ، لا تعرض هذا الجهاز للمطر أو الرطوبة. لا تقم بتركيب الجهاز في أماكن المبللة أو رطبة بدون استخدام معدات الحماية من الطقس من Meyer Sound



تحذير: يجب توصيل أجهزة من الفئة ١ بمأخذ التيار الكهربائي باستخدام وصلة تأريض واقية



حذر: افصل قابس التيار الكهربائي قبل فصل سلك الطاقة عن



- اقرأ هذه التعليمات
- احتفظ بهذه التعليمات
- انتبه إلى جميع التحذيرات
- اتبع جميع التعليمات
- لا تستخدم هذا الجهاز بالقرب من الماء
- نظف بقطعة قماش جافة فقط
- لا تسد أي فتحات تهوية. قم بالتثبيت وفقاً لتعليمات التثبيت من الشركة المصنعة
- لا تقم بالتركيب بالقرب من أي مصادر حرارة مثل المشاعيع (الرادياتور) أو منافذ التدفئة أو المواقد أو أي جهاز آخر ينتج عنه حرارة
- لا تلغي غرض السلامة الخاص بقابس التأريض. يحتوي قابس التأريض على شفتين وشق أرضي ثالث. يتم توفير الشق الثالث من أجل سلامتك. إذا كان القابس المرفق لا يتناسب مع المنفذ لديك ، فاستشر كهربائياً لاستبدال القابس الحالي
- قم بتوصيل الجهاز بمقبس رئيسي ثنائي القطب وثلاثي الأسلاك. يجب توصيل الوعاء بفتيل أو قاطع دائرة. يشكل الاتصال بأي نوع آخر من الأوعية خطر حدوث صدمة وقد ينتهك الرموز الكهربائية المحلية
- لتقليل خطر التعرض لصدمة كهربائية ، افصل الجهاز عن مصدر التيار المتردد قبل تركيب كبل الصوت. أعد توصيل سلك الطاقة فقط بعد إجراء جميع توصيلات الإشارة
- احم سلك الطاقة من السير عليه أو الضغط عليه ، خاصةً عند القوابس ومآخذ التوصيل ونقطة خروجها من الجهاز. يجب أن يظل قابس التيار الكهربائي المتردد أو قارئة الأجهزة سهلة الوصول للتشغيل
- استخدم فقط المرفقات / الملحقات المحددة من قبل الشركة المصنعة. استخدم فقط مع قضبان العجلات أو المعدات المحددة من قبل الشركة المصنعة ، أو تباع مع الجهاز. المقابض للحمل فقط

סמלים אלה מציינים מאפייני בטיחות או תפעול חשובים בחוברת זו ועל המסגרת או השלדה

							
מתחים מסוכנים סכנת התחשמלות	הוראות הפעלה חשובות	חיבור הארקה מגן	משטח חם לא לגעת	הוראות שימוש אלקטרוניות מיקום ההוראות בקוד	כניסת זרם חילופין	יציאת אודיו בתקן מילאן	כניסת שמע אנלוגית פלט לולאת שמע אנלוגי
							

### הוראות בטיחות חשובות

- נתק מכשיר זה במהלך סופות ברקים או כאשר אינו בשימוש לפרקי זמן ארוכים
- אם מצויד במחזיק נתיך חיצוני, הנתיך הניתן להחלפה הוא הפ-ריט היחיד שניתן לשירות על ידי המשתמש. בעת החלפת הנתיך, השתמש רק באותו סוג ובאותו ערך
- הפנה כל טיפול נוסף לצוות שירות מוסמך. שירות נדרש כאשר המכשיר ניזוק בכל דרך שהיא, כגון כאשר כבל אספקת החשמל או התקע נפגע, נוזל נשפך או חפצים נפלו לתוך המכשיר, גשם או לחות חדרו למכשיר, המכשיר נפל, או כאשר מסיבות לא ידועות המכשיר אינו פועל כרגיל
- **אזהרה!** עבור ספקי כוח Meyer Soundt IntelligentDC MPS-488X, MPS-488HP, MM-10ACX ועבור רמקול MPS-482HP החיווט החיצוני המחובר אל יציאות המכשיר דורש התקנה על ידי אדם מוסמך ו/או שימוש בכבלים מוכנים מראש
- **אזהרה!** כדי להפחית את הסיכון של שריפה או התחשמלות, אל תחשוף את המכשיר לגשם או לחות. אין להתקין את המכשיר במקומות רטובים או לחים ללא שימוש בצידוד הגנה מפני מזג האוויר של Meyer Sound
- **אזהרה!** מחשירי Class I יחובר לשקע עם חיבור הארקה מגן
- **אזהרה!** נתק את תקע החשמל משקע החשמל לפני ניתוק כבל החשמל מהרמקול
- קרא את ההוראות האלה
- שמור את ההוראות האלה
- שימו לב לכל האזהרות
- בצע את כל ההוראות
- אל תשתמש במכשיר זה ליד מים
- נקה רק עם מטלית יבשה
- אין לחסום פתחי אוורור. התקן לפי הוראות ההתקנה מ Meyer Sound
- אין להתקין ליד מקורות חום כלשהם כגון רדיאטורים או מכשירי חום אחרים
- אל תעקוף את יכולות הבטיחות של תקע בעל הארקה. לתקע מוארק יש שתי שיניים - ושן נוספת לארקה. שן הארקה מסופקת לבטיחותך. אם התקע שסופק לא מתאים לשקע שלך - התייעץ עם חשמלאי להחלפתו
- חבר את המכשיר לשקע רשת מוארק - דו קוטבי בעל 3 גידים
- השקע חייב להיות מחובר לנתיך או למפסק. חיבור לכל סוג שקע אחר מהווה סכנת התחשמלות ועלול להפר את חוקי החשמל המקומיים
- כדי להפחית את הסיכון להתחשמלות נתק את המכשיר מרשת החשמל לפני התקנת כבל שמע. חבר מחדש את כבל החשמל רק לאחר חיבור כל כבלי השמע והאות
- הגן על כבל החשמל מפני דריכה או התקלות, במיוחד בתקעים, בשקעי נוחות ובנקודה שבה הם יוצאים מהמכשיר. תקע החשמל או מתאם המכשיר יישארו נגישים לתפעול
- השתמש רק בהרחבות/אביזרים שצוינו על ידי היצרן. השתמש רק בעגלות ובצידוד תלייה שצוין על ידי היצרן או נמכר עם המכשיר. הידיות מיועדות לנשיאה בלבד

# CONTENTS

<b>Safety Instructions</b>	<b>iii</b>
<b>Introduction</b>	<b>1</b>
How To Use This Manual	1
2100-LFC Low Frequency Control Element	1
<b>Safety Statement For Rigging</b>	<b>3</b>
<b>Power Requirements</b>	<b>5</b>
AC Power Distribution	5
Branch Circuits	5
120 V AC, 3-Phase Wye System (Two Lines)	5
230 V AC, 3-Phase Wye System (Single Line)	6
AC Input	6
Assembly of Power Cables	6
2100-LFC Voltage Requirements	7
Circuit Breaker Requirements	7
Power Supply	8
Electrical Safety Guidelines	8
<b>Amplification and Audio</b>	<b>9</b>
Audio Connectors	9
Analog	9
Milan Endpoint Module	10
Digital Audio Input	10
Telemetry	11
Wink Function	11
2100-LFC Cooling System	12
Cable Rings	12
<b>2100-LFC Rigging</b>	<b>13</b>
<b>MTG-2100 Top Grid Kit</b>	<b>14</b>
MTG-2100 Grid Kit Contents	14
MTG-2100 Load Ratings	14
MTG-2100 Grid Hardware Connections	14
<b>2100-LFC GuideALinks</b>	<b>16</b>
<b>MCF-2100 Caster Frame</b>	<b>17</b>
Safety Guidelines for the MCF-2100 Caster Frame	18

## CONTENTS (CONT.)

<b>Assembling Arrays</b>	<b>19</b>
User Provided Equipment	19
Array Assembly Preparation	19
Array Assembly Steps	19
Stacking Caster Frames	22
Outdoor Use	23
<b>Disassembling Arrays</b>	<b>24</b>
Array Disassembly Preparation	24
Array Disassembly Steps	24
<b>Compliance</b>	<b>26</b>
<b>Specifications</b>	<b>27</b>

## INTRODUCTION

### HOW TO USE THIS MANUAL

Read these instructions in their entirety before configuring and deploying a Meyer Sound loudspeaker system. Pay close attention to safety related information.

As you read these instructions, you will encounter the following icons for notes, tips, and cautions:



**NOTE:** A note identifies an important or useful piece of information relating to the topic under discussion



**TIP:** A tip offers a helpful tip relevant to the topic at hand.



**CAUTION:** A caution gives notice that an action may have serious consequences and could cause harm to equipment or personnel, or could cause delays or other problems.

Information and specifications are subject to change. Updates and supplementary information are available at:

- [meyersound.com/products](https://meyersound.com/products)
- [meyersound.com/documents](https://meyersound.com/documents)

Meyer Sound Technical Support is available at:

- [meyersound.com/contact](https://meyersound.com/contact) (recommended)
- M-F 9 am to 5 pm PT +1 510 486 1166
- After Hours Product Usage Inquiries Only  
+1 866 773 1096

### 2100-LFC LOW FREQUENCY CONTROL ELEMENT

The self-powered 2100-LFC Low Frequency Control Element, is designed to extend the response of a system with a native frequency response of 30 - 125 Hz. The combination of the Class D amplifier, a single 21-inch driver with four voice coils, and advanced cabinet design delivers linear reproduction for the most demanding applications.

The 2100-LFC is designed to be deployed alongside Meyer Sound products, including the PANTHER models.

Meyer Sound's Nebra software is used to monitor telemetry data, which is transmitted via the network connection. The Wink function identifies loudspeakers listed in software.



Figure 1. 2100-LFC Low Frequency Control Element

The high output switch-mode power supply reduces weight and is more efficient than linear power supplies. The operating voltage is 200-240 V AC, 50-60 Hz.

Both analog and Milan AVB audio inputs and the power inlet are provided on the rear user panel.

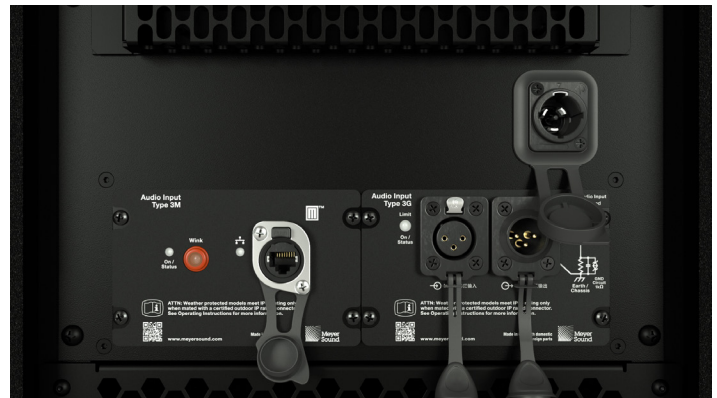

Figure 2. 2100-LFC User Panel, Sealing Caps Open

The user panel connectors are all from the Neutrik True Outdoor Protection (TOP) product line. An IP65 rating is achieved for the connectors only when the connected cables are also terminated with Neutrik TOP connectors or when the sealing caps are properly seated.



Figure 3. 2100-LFC User Panel, Sealing Caps Seated

Each loudspeaker ships with the corresponding cable-mount Neutrik TOP connectors (power, XLR, and network) for use when terminating cables.

**NOTE:** Because the connectors and amplifier module have been designed to be exposed to the elements and resist water intrusion, a rain hood accessory is not needed or available.

**NOTE:** To optimize the acoustical performance of a 2100-LFC array, use the appropriate number of loudspeakers to meet the coverage and output requirements. Meyer Sound's MAPP System Design and Prediction software provides the capabilities to determine the optimal array configuration.

The MTG-2100 Grid Kit connects the top 2100-LFC of an array to hoisting equipment.



Figure 4. MTG-2100 Grid Kit

MCF-2100 Caster Frames facilitate transport logistics. Two loudspeakers and the grid or three loudspeakers can be safely transported. Two and three-high covers are available.



Figure 5. MCF-2100 Caster Frame



## SAFETY STATEMENT FOR RIGGING

Please read this statement carefully and in its entirety. It contains important information regarding safety issues, including guidelines for general safe use of rigging systems as well as advisories on government regulations and liability laws.

This Statement assumes that the owners and/or users of a Meyer Sound QuickFly® system are knowledgeable and experienced in the areas of rigging and flying loudspeaker systems. Many issues of crucial concern, such as the determination of appropriateness and condition of venue rigging points, cannot be addressed here. Therefore, the user must assume all responsibility for the appropriate use of QuickFly systems in any particular location or circumstance.

The suspension of large, heavy objects in public places is subject to numerous laws and regulations at the national/federal, state/provincial, and local levels. The user must assume responsibility for making sure that use of any QuickFly system and its components in any particular circumstance or venue conforms to all applicable laws and regulations in force at the time.

### Load Ratings and Specifications

Long-term safe operation is a central concern in the design and manufacture of any rigging/flying system. Meyer Sound has taken great care in material selection and component design. After manufacture, all load-critical system components are individually inspected. All load ratings and other specifications are the result of accepted engineering practice and careful testing.

To analyze load ratings, use Meyer Sound's MAPP System Design and Prediction Tool. MAPP supports custom input of Meyer Sound loudspeaker system configurations and determines safety in 5:1.

Users are advised to check [meyersound.com](http://meyersound.com) or contact Technical Support at regular intervals to check for updates.

### Regulatory Compliance

The design and working load limit (WLL) ratings of the QuickFly system are intended to be in compliance with all known regulatory statutes currently applicable in the United States. However, as noted above, there are wide variations internationally in the regulations and practices applying to suspension of sound systems in public places. Although regulations in the United States are generally among the most stringent, safety codes may be even stricter in a few localities (such as those highly prone to earthquakes). In addition, applicable safety codes are open to interpretation:

Government officials in one location may have a stricter interpretation than another local official, even when operating under the same regulations and in the same legal jurisdiction.

### Safety Responsibilities "Above the Hook"

In most touring applications of rigging systems, the audio equipment provider is normally responsible for ensuring the safety of the suspension system only below the attachment point. The safety and suitability of the attachment point above the uppermost Meyer Sound product is generally seen as the responsibility of the venue owner or operator. However, this distinction ("above the hook" versus "below the hook") can be open to interpretation. Touring system operators should make certain that attachment points are approved and suitably load rated, and that the points used are those identified as such by the venue owner or engineer of record. As an extra precaution, careful inspection of the attachment points is advised before attaching a load, particularly in older venues or those hosting frequent events using large sound and lighting systems. IN ANY CASE, MEYER SOUND QUICKFLY SYSTEMS ARE INTENDED ONLY FOR SUSPENSION FROM APPROVED RIGGING POINTS, EACH KNOWN TO HAVE AMPLE WLL MARGINS FOR THE SYSTEM COMPONENTS SUSPENDED BELOW THEM.

### Inspection and Maintenance

The Meyer Sound QuickFly systems are an assembly of mechanical devices, and are therefore subject to wear and tear over prolonged use, as well as damage from corrosive agents, extreme impact, or inappropriate use.

BECAUSE OF THE SAFETY ISSUES INVOLVED, USERS MUST ADOPT AND ADHERE TO A SCHEDULE OF REGULAR INSPECTION AND MAINTENANCE. IN TOURING APPLICATIONS, KEY COMPONENTS MUST BE INSPECTED BEFORE EACH USE. Such inspection includes examination of all load-bearing components for any sign of undue wear, twisting, buckling, cracking, rusting, or other corrosion. In regard to rust and corrosion, the main components of a QuickFly system are either protected by an exterior coating or made from stainless steel, which is resistant to rust and resistant to most corrosive fluids. Nevertheless, normal use and shipping vibrations can wear through the protective coatings, and extremely corrosive fluids (such as battery acid) can cause severe damage with prolonged exposure even to protected parts. Particular attention should be given to pins, screws, bolts, and other fasteners to make certain the fittings are tight and secure. Metal seams and welds should be examined for any sign of separation or deformation. Meyer Sound strongly recommends that written documentation be maintained on each QuickFly system, noting date of

inspection, name of inspector, points of system checked, and any anomalies discovered.

## Annual Comprehensive Examination and Test Program

In addition to routine checks on the road for touring systems, Meyer Sound also recommends a careful, comprehensive system examination and testing “at home” in the warehouse or other appropriate location at regular intervals. Such at home examinations and tests should occur at least once a year, and should include a careful inspection of each component under ideal lighting conditions, and then a final comprehensive check of the entire system after it has been flown.

If any anomalies or defects are discovered that could possibly affect the safety or integrity of the system, affected parts or subsystems should be replaced in their entirety before that part of the system is flown again.

## Replacement Parts

Any component found to be defective, or any safety-related component even suspected of being defective, should be replaced with the equivalent, approved part. Parts specific to a QuickFly system should be ordered directly from Meyer Sound. No attempt should be made to substitute what appears to be equivalent or “mostly the same” generic replacements. Some parts used in QuickFly systems are identical to those used in other rigging applications. To the best of our knowledge, most of these suppliers are reputable and their products are reliable. However, Meyer Sound has no way of assuring the quality of products made by these various suppliers. Therefore, Meyer Sound is not responsible for problems caused by components that were not supplied by Meyer Sound.

## Training

QuickFly systems are relatively straightforward and easy to use. However, they should only be used by persons trained in the use of loudspeaker rigging systems, who have mastered key points of assembly, rigging and flying.

## MAPP

MAPP assumes the top grid is picked up by a front and rear motor along the perimeter of the grid, directly to the middle or outer pickup points, but not to the center bar pickup points. Other rigging configurations may have reduced load capacity. These cases should be reviewed by proper personnel to verify load capacities for alternate configurations.

## Limitations and Disclaimer

The safety limit analysis provided by MAPP does not apply, and may not be relied upon, if the loudspeaker system (1) has been improperly installed or maintained, (2) the rigging or loudspeakers of the system have been damaged prior to installation, (3) the indicated configuration of the system has been altered, (4) any weight has been added to the indicated configuration, or (5) the system is in an outdoor venue and remains installed during strong wind conditions. MEYER SOUND ASSUMES NO RESPONSIBILITY FOR ANY PART OF AN INSTALLATION “ABOVE THE HOOK” OR WHERE ANY OF THE FOREGOING LIMITATIONS APPLY.





## POWER REQUIREMENTS

Understanding power distribution, voltage and current requirements, and electrical safety guidelines is critical to the safe operation of 2100-LFC loudspeakers.

Sufficient power must be provided for the loudspeakers to accurately reproduce the full dynamic range of the input signal, especially during periods of maximum acoustic output.

### AC POWER DISTRIBUTION

All components in an audio system (self-powered loudspeakers, mixing consoles, processors, etc.) must be properly connected to an AC power distribution system, ensuring that AC line polarity is preserved. All the grounding points of the audio system components must be connected to a single node or common point using the same cable gauge (or larger) as the neutral and line conductors.

-  **CAUTION:** The nominal operational AC mains voltage range is 200–240 V AC.
-  **CAUTION:** The voltage between the earth/ground and line should never exceed 264 V AC or be less than 160 V AC.
-  **CAUTION:** Before applying AC power to any Meyer Sound self-powered loudspeaker, make sure the voltage potential difference between the neutral and earth/ground conductors is less than 5 V AC when using single-line AC wiring (LINE - NEUTRAL - EARTH/GROUND).
-  **CAUTION:** The earth/ground conductor must always be used for safety reasons.
-  **CAUTION:** Improper earthing/grounding of connections between loudspeakers and the rest of the audio system may produce noise or hum or cause serious damage to the input and output stages of the system's electronic components.

### BRANCH CIRCUITS

To reduce the number of branch circuits, it is common to connect two 2100-LFC loudspeakers to one branch circuit, provided the circuit breaker is sufficiently rated. To reduce the impedance of the conductors, minimize the length of cable after the branch circuit has been “split.” Typically, a single circuit cable is split very near the loudspeakers using a molded split, junction box, or wye cable.

### 120 V AC, 3-PHASE WYE SYSTEM (TWO LINES)

#### Line-Line-Earth/Ground

Figure 6 illustrates the secondary of a 120/208 V AC, 3-phase Wye distribution system. Each loudspeaker is connected to two lines and the earth/ground. This configuration is possible because 2100-LFC loudspeakers tolerate elevated voltages from the earth/ground conductor and does not require a neutral line. This distribution system delivers 208 V AC to each loudspeaker.

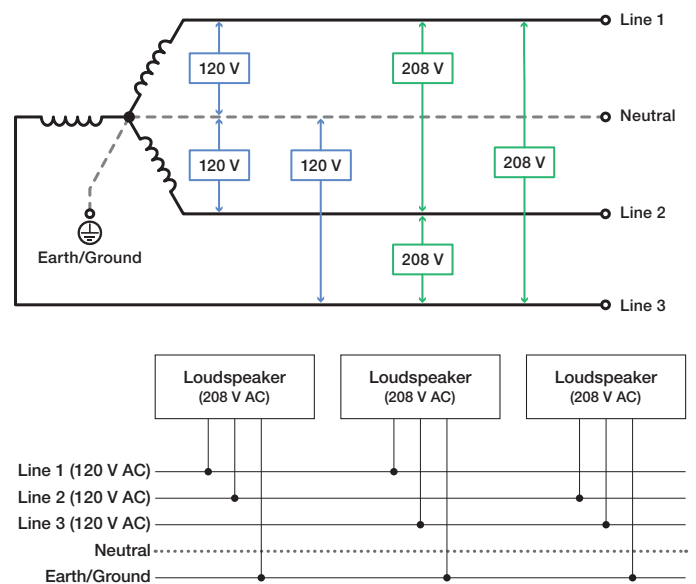



Figure 6. Three-Phase, 120/208 Volt AC Transformer Secondary, Wye Configuration and Loudspeaker Connections

-  **CAUTION:** Do not connect a 2100-LFC loudspeaker to only one line of a 120/208 V AC Wye service as the voltage delivered will be 120 V AC, below the operating voltage range.

## 230 V AC, 3-PHASE WYE SYSTEM (SINGLE LINE)

### Line-Neutral-Earth/Ground

Figure 7 illustrates the secondary of a 230/400 V AC, 3-phase Wye distribution system. Each loudspeaker is connected to one of the lines, the neutral, and the earth/ground. This distribution system delivers 230 V AC to each loudspeaker.

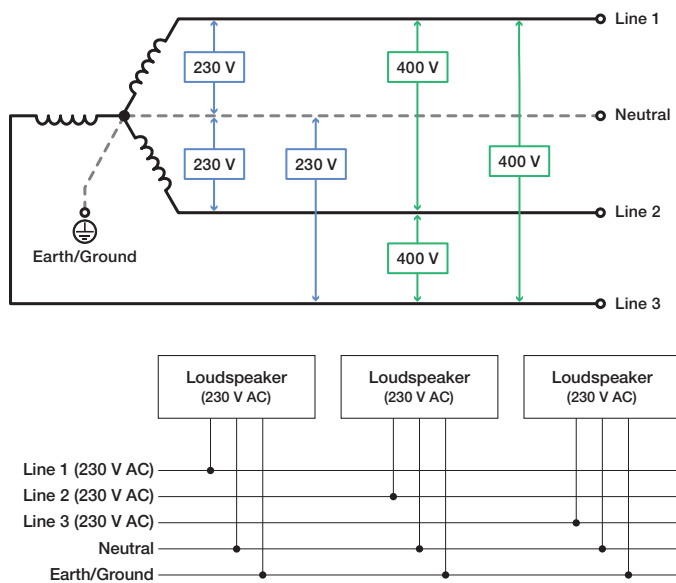

Figure 7. Three-Phase, 230/400 Volt AC Transformer Secondary, Wye Configuration and Loudspeaker Connections

**CAUTION:** For 230/400 V AC, 3-phase Wye systems, never connect two lines to the AC input of 2100-LFC. 400 V AC significantly exceeds the upper voltage limit of 264 V AC and will damage the loudspeaker.

## AC INPUT

The 2100-LFC user panel includes an AC inlet connector. The 3-conductor Neutrik powerCON TRUE1 True Outdoor Protection (TOP) locking connector supplies electrical power to the loudspeaker (Figure 8).

**CAUTION:** Presence of water or other conductive liquids in the AC connectors creates a shock/electrocution hazard.

**CAUTION:** The inlet connector is certified for outdoor protection (IP65, UL50E) only when mated with a Neutrik powerCON TRUE1 TOP cable-mount connector, or when the connector is not in use, when the sealing cap is fully inserted.

**CAUTION:** Check the sealing cap for moisture before covering the connector. If wet, dry the cap before covering the connector to avoid introducing liquid to the connector.



Figure 8. User Panel, Power Inlet, Neutrik powerCON TRUE1 TOP Connector

The powerCON True 1 TOP connectors can be engaged or disengaged while the circuit is energized without damaging the connectors over time, provided both connectors are rated for energized connection.

**CAUTION:** Make sure the AC inlet connector assembly is secure and has not been damaged during prior use or transportation before connecting the power cable.

## ASSEMBLY OF POWER CABLES

A cable-mount Neutrik powerCON TRUE1 TOP connector is included with each 2100-LFC loudspeaker (Neutrik NAC3FX-W-TOP) enabling users to assemble power cables to meet their needs.

**CAUTION:** Correct assembly of the powerCON TRUE1 TOP connectors is required to achieve the IP65 rating, preventing water ingress. Improperly assembled connectors pose a shock/electrocution hazard.

Visit the Neutrik website ([neutrik.com](http://neutrik.com)) to download the cable preparation and connector assembly instructions for the powerCON TRUE1 TOP NAC3FX-W-TOP cable-mount connector.

**CAUTION:** For 2100-LFC power cables, all conductors must be 12 AWG (2.5 mm<sup>2</sup>).

Use only cable with an outer jacket diameter between 1/4-in [6 mm] and 1/2-in [12 mm].

For the inlet end of the cable, the plug must be rated for at least the current draw of a 2100-LFC (1200 watts divided by supply voltage) and be approved for use in the region where the product will be used.

The pins of the powerCON TRUE1 TOP cable mount connector are labeled as follows:

- L (Line)
- N (Neutral)
- Ⓧ (Protective Earth or Ground)

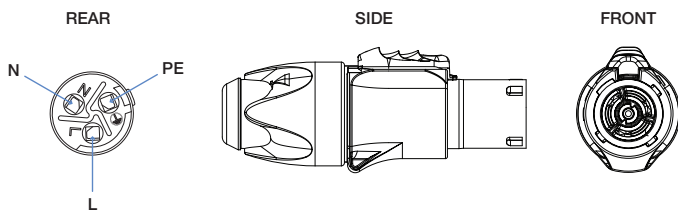

Figure 9. Neutrik powerCON TRUE1 TOP Cable Mount Connector

**CAUTION:** Careful attention should be paid when terminating these connectors to ensure the proper conductor of the cable is connected to the intended terminal. The terminal identification markings inside the connector can be difficult to identify. After terminating the conductors, we strongly advise using a continuity meter to verify the proper connections are made, preventing a shock hazard and/or damage to the loudspeaker.

How AC power cables are wired is determined by the type of AC power distribution system used (see “AC Power Distribution” on page 5).

**CAUTION:** When wiring AC power cables and distribution systems, it is important to preserve AC line polarity and connect the earth ground at both ends of the cable.

## 2100-LFC VOLTAGE REQUIREMENTS

The AC mains voltage range at the loudspeaker AC inlet must be between 160 V AC and 264 V AC while the loudspeaker is operating, including periods of peak acoustic output when the loudspeaker draws maximum current.

Because the 2100-LFC behaves as a constant power load, current increases if the voltage decreases at its AC inlet. The maximum round-trip resistance of the cable for a single 2100-LFC should not exceed 5 Ohms for a 230 V AC source voltage because the AC Mains voltage will fall below 160 V AC at the AC inlet.

**CAUTION:** 2100-LFC may be damaged or may malfunction if the inlet voltage is greater than 264 V AC or less than 160 V AC.

## CIRCUIT BREAKER REQUIREMENTS

The circuit breakers used in the Meyer Sound MDM-5000 are well suited for use with 2100-LFC loudspeakers and other Meyer Sound products:

- European MDM-5000 includes ETI model number: KZS-1M 1p+N A C16/0.03, 6kA, which includes an RCD (residual current device) with a C-type tripping time constant and 30 mA RCD.
- US MDM-5000 includes Eaton model: QCR2020 - CIRCUIT BREAKER 2-Pole, 20 A, 120/240 V AC

Circuit protection devices for main and branch circuits of any power distribution system used in conjunction with 2100-LFC loudspeakers should use similarly specified devices to avoid nuisance tripping.

**NOTE:** Many RCCB's (residual current circuit breakers) are sensitive to high-frequency noise in the Line-Neutral path and may false/nuisance trip. If required, make sure residual current devices are not sensitive to high-frequency noise or artifacts. Conductor-to-conductor capacitance can cause an imbalance between the current carrying conductors in a cable or a conduit, potentially causing RCCB nuisance tripping. Consult with a licensed electrician or electrical engineer when designing electrical distribution systems.

## POWER SUPPLY

The 2100-LFC's power supply eliminates high inrush currents with soft-start power up, suppresses high-voltage transients up to several kilovolts, and filters common mode and differential mode radio frequencies (EMI).

### Powering on 2100-LFC

When powering on 2100-LFC, the following startup events take place over several seconds:

- The Active/Status LEDs flash during initial startup.
- When both the Active/Status LEDs turn solid green, the loudspeaker is unmuted and ready to reproduce audio.

 **CAUTION:** If the Active/Status LEDs do not turn solid green after 30 seconds, remove AC power and verify that the voltage is within the required range and the conductors of the power cable are connected to the proper terminals of the connectors. If the problem persists, contact Meyer Sound Technical Support.

 **CAUTION:** If the Active/Status LEDs pulse red or yellow after the loudspeaker has been powered on longer than 30 seconds, an error has been detected. The details of the error are reported in Meyer Sound's Nebra software via the network connection.

## ELECTRICAL SAFETY GUIDELINES

Make sure to observe the following important electrical and safety guidelines.

- Do not operate the unit if the power cable is frayed or broken.
- Use the cable rings on the rear of the cabinet to reduce strain on the connected cables. Do not use the cable rings for any other purpose.

## AMPLIFICATION AND AUDIO

The user panel located on the rear of 2100-LFC loudspeakers includes audio input connectors, one for analog audio, the other for Milan AVB digital audio.



Figure 10. 2100-LFC User Panel, Audio Inputs, Sealing Caps Not Depicted

Both audio inputs are always active. If signal is present at both inputs, both signals are reproduced. When using one input as a backup to the other, utilizing GALAXY processor input or output mutes is one strategy to switch between input types.

**NOTE:** Using Groups and Controls in Compass, a single control button can be assigned to toggle some or all the input or output mutes of a Galileo GALAXY processor or processors.

The analog and Milan inputs will arrive at the loudspeaker at different times due to transport time of the Milan signal through the network, usually less than 2 ms. The latency of the Milan signal is dependent on the number of network switch hops and the presentation time set in software. To synchronize the signals, determine the time offset and add that amount of delay to the signal reproduced earliest, usually the analog input signal.

If one input is used as a backup, time aligning it with the primary input provides a smoother transition when the signal to the primary input is muted and the backup is unmuted. Synchronizing the inputs also preserves the time alignment with other system components regardless of which input is receiving signal.

### AUDIO CONNECTORS

The user panel includes two 3-pin Neutrik XLR True Outdoor Protection (TOP) connectors for analog audio input and audio loop output. The network connector is a Neutrik etherCON True Outdoor Protection (TOP).

**CAUTION:** The analog and network chassis connectors are certified for outdoor protection (IP65, UL50E) only when mated with the Neutrik TOP cable-mount connectors, or when the connector is not in use, when the sealing cap is fully inserted.

**CAUTION:** Check the sealing caps for moisture before covering the connectors. If wet, dry the caps before covering the connectors to avoid introducing liquid into the connectors.

**CAUTION:** Always seal the connectors with the sealing caps when the connectors are not in use.

### Analog Audio Input (XLR 3-Pin Female)

The XLR 3-pin female connector labeled “Input” accepts balanced audio signals with an input impedance of 10 kOhm. The connector uses the following wiring scheme:

- Pin 1 — 1 kOhm to chassis and earth ground (ESD clamped)
- Pin 2 — Signal (+)
- Pin 3 — Signal (–)
- Case — Earth (AC) ground and chassis

Pins 2 and 3 carry the input as a differential signal. Pin 1 is connected to earth through a 1 kOhm, 1000 pF, 15 V clamped network. This circuitry provides virtual ground lift for audio frequencies while allowing unwanted signals to bleed to ground. Make sure to use balanced XLR audio cables with pins 1, 2, and 3 connected on both ends. Connecting the signal ground at only one end is not recommended. Shorting the signal ground conductor to the connector case may cause a ground loop, resulting in hum.

**NOTE:** If unwanted noise or hiss is produced by the loudspeaker, disconnect the audio signal cable from the loudspeaker input. If the noise stops, there is most likely nothing wrong with the loudspeaker. To locate the source of the noise, check the audio cable, source audio, AC power, and electrical ground.

## Analog Audio Loop (XLR 3-Pin Male)

The XLR 3-pin male connector labeled “Loop” allows multiple loudspeakers to be looped from a single audio source. This connector uses the same wiring scheme as the input connector. For applications that require one drive line to provide signal to multiple 2100-LFC loudspeakers, connect the output of the first loudspeaker to the input of the next loudspeaker, and so forth.

 **NOTE:** The connector labeled “Loop” is wired in parallel to the input connector and transmits the unbuffered source signal whether the loudspeaker is powered on or off.

## Calculating Analog Input Load Impedance

To avoid distortion when looping multiple loudspeakers, make sure the source device can drive the total load impedance of the looped loudspeakers. In addition, the source device must be capable of producing +24 dBu into 50 Ohms to produce the maximum peak SPL over the operating bandwidth of the loudspeaker.

To calculate the load impedance for the looped loudspeakers, divide 10 kOhms (the input impedance for a single loudspeaker) by the number of looped loudspeakers. For example, the load impedance for ten 2100-LFC loudspeakers is 1000 ohms (10 kOhms / 10). Most source devices are capable of driving loads no less than 10 times their output impedance. To drive this number of looped loudspeakers, the source device should have an output impedance of 100 ohms or less (1000 ohms / 10). Galileo GALAXY outputs have an output impedance of 50 ohms, capable of driving the load of up to 20 loudspeakers with 10 kOhm inputs without distortion.

 **CAUTION:** Make sure all cabling for looped loudspeakers is wired correctly (Pin 1 to Pin 1, Pin 2 to Pin 2, and so forth) to prevent the polarity from being unintentionally reversed. If one or more loudspeakers in a system receive audio signals that are of the opposite polarity, frequency response and coverage will be significantly degraded.

## Milan Endpoint Module

The Milan Endpoint module (Type 3M Audio Input Module, Figure 11) includes a Neutrik etherCON TOP connector, an Ethernet connectivity LED, an On/Status LED, and a Wink button/LED.

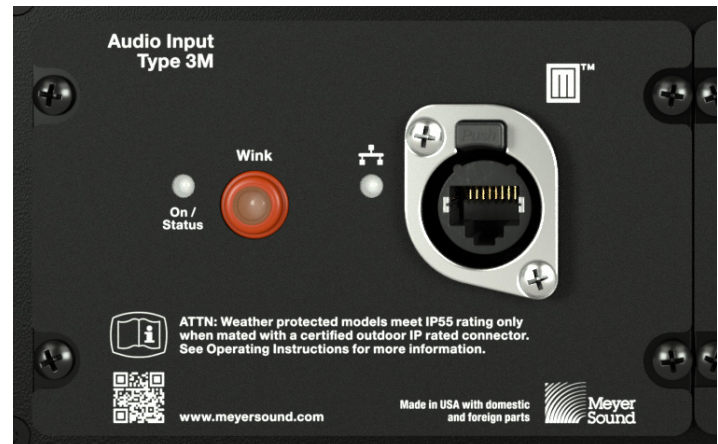



Figure 11. 2100-LFC User Panel, Milan Endpoint Module

## Network Connector

The etherCON TOP connector provides the network connection for transmission of a digital audio signal to the loudspeaker and the transmission of telemetry data from the loudspeaker.

 **TIP:** Use an Avnu-certified network switch when the Milan digital audio input is used. For a list of Avnu certified AVB switches please refer to the certification pages at [avnu.org](http://avnu.org).

When the Milan input is not used, a standard Ethernet network (IEEE 802.3 compliant, supporting at least 100 MB/s, full-duplex) is capable of transmitting the telemetry data.

## Digital Audio Input

The Milan Endpoint accepts a single channel of a Milan digital audio stream as specified by the Avnu Alliance. To utilize the Milan input, connect the loudspeaker to an Avnu-certified network switch.

When a Milan Endpoint loudspeaker and a computer are connected to the same network via an Avnu-certified network switch, the loudspeaker will be listed in Meyer Sound’s Nebra software or other AVB controller software. The Milan Endpoint loudspeaker (Listener) must be assigned to an available audio source channel (Talker) for the loudspeaker to reproduce the audio stream transmitted by the Talker.



For Milan audio transport, the network connection speed between the last network switch and a Milan Endpoint is 100 bT, 100 Mb/ second. The connection speed between network switches transporting Milan digital audio signals is 1000 bT, 1 G/second.

## Telemetry

Loudspeakers with Milan Endpoints transmit telemetry data via the network connection. To view the telemetry data, connect the loudspeaker(s) and a computer to a network switch. The loudspeaker telemetry data is displayed in Meyer Sound's Nebra software which displays extensive system status and performance data for each loudspeaker, including amplifier voltage, limiting activity, power output, fan speed and driver status. A mute function is available.

An Avnu-certified switch is not necessary when the network is only transporting telemetry data. When the network only transports telemetry data, the connection speed from end-to-end is 100 bT, 100 Mb/second.

## Wink Function

The Wink function facilitates the identification of physical loudspeakers listed in Meyer Sound's Nebra software. When making digital audio signal connections in software, it's necessary to know which physical loudspeaker the signal is routed to. A network connection between the loudspeaker and a computer running Nebra software is required.

When active, the Wink function is indicated in four locations: Nebra software, the Wink push-button on the user panel of the loudspeaker, the LED bar on the amplifier cowl, and two LED strips on the front of the cabinet.

Once a Milan Endpoint has been detected and auto-discovered in Nebra software, the loudspeaker's detail page includes a button with an icon of an eye. Clicking this button toggles the Wink function, which is indicated in the software. When the Wink function is active, the Wink push-button on the user panel of the loudspeaker, the LED bar on the amplifier cowl, and the two LED strips on the front of the loudspeaker illuminate. The wink function times out after 10 seconds.

## Wink/Activity LED (Green)

To activate the Wink function from the loudspeaker, press and hold the Wink button down while observing the On/Status LED, which turns red and then off. Release the Wink button when the On/Status LED turns off, activating the Wink function. The Wink LED turns green for 10 seconds. If the Wink button remains depressed, the On/Status LED will turn red again and the Wink function will remain off.

To turn off the Wink function, wait 10 seconds for it to time out or depress and hold the Wink button, the On/Status LED will turn red. Wait until the On/Status LED turns off, then release the Wink button.



Figure 12. On/Status LED, Wink Button/LED, Network Connectivity LED, and Network Connector.

## Ethernet/Network Connectivity LED

The Ethernet connectivity LED (immediately to the left of the network connector) turns solid yellow when a 100 bT link is established; otherwise, it is off.

## On/Status and Limiting Indication

During normal operation, when 2100-LFC is powered on, the On/Status LED on the user panel is solid green. Limiting activity is indicated by the On/Status LED illuminating yellow while limiting is active.

When limiting is engaged, the channel's gain is reduced. The limiter protects the driver and prevents signal peaks from causing excessive distortion in the amplifier, thereby preserving headroom and maintaining a smooth frequency response at high levels. When source levels return to normal, below the limiter's threshold, the LED turns green and limiting ceases.

The loudspeaker performs within its acoustical specifications at normal temperatures when the On/Status LED is green, or when limiting is not continuous. During continuous limiting, the loudspeaker is nearing its operational limits, resulting in the following effects:

- Increases to the input level have no effect.
- Distortion increases due to clipping and nonlinear driver operation.
- The drivers are subjected to excessive heat and excursion, which compromises their life span and may eventually damage them.

**CAUTION:** The On/Status LED indicates when a safe, optimum level is exceeded. If a 2100-LFC loudspeaker system begins to limit before reaching the desired acoustic output, consider adding more loudspeakers to the system.

## 2100-LFC COOLING SYSTEM

The 2100-LFC employs forced-air cooling with variable-speed fans to prevent the amplifier or driver from overheating. The amplifier module fans draw air in through the inlet grille on the rear below the user panel and through the vent at the bottom of the amplifier cowl. The exhaust exits through the upper-left exhaust vent next to the user panel. The driver cooling system draws air through the lower-left inlet grille, which exits via the front-facing acoustic chamber ports (Figure 13).

The two vent grilles to the right of the user panel are provisional, not functional.

**CAUTION:** To keep 2100-LFC from overheating, allow at least six inches (15 cm) of space with unobstructed airflow behind the enclosure for proper ventilation.

**CAUTION:** Regularly inspect the foam and screen behind the air intake grilles located below the user panel, at the bottom of the amplifier cowl, and the lower-left intake next to the user panel. If a significant amount of particulate has accumulated on the screen or foam, power down the loudspeaker for at least one minute and remove the cover of the contaminated intake(s). Vacuum, then rinse the screen and foam with water until the particulate is removed. Allow the screen and foam to dry completely, then reassemble.

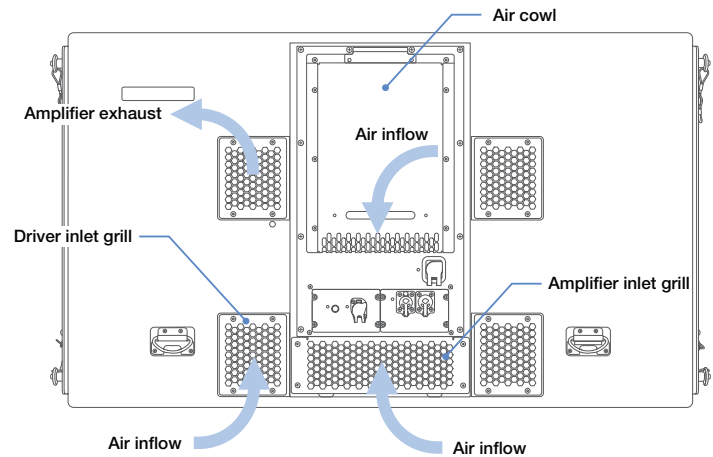

Figure 13. 2100-LFC Amplifier Ventilation

**CAUTION:** If a system being operated in a hot environment includes 2100-LFC loudspeakers and the telemetry data (Nebra software) indicates very high thermal conditions, consider adding more loudspeakers to the system.

**TIP:** When 2100-LFC is connected to a network, Meyer Sound's Nebra software displays telemetry metrics, including the fan status and operating temperature.

## CABLE RINGS

Two cable rings are provided on the rear of the 2100-LFC cabinet. Power and audio cables should be tied off to these rings to reduce strain and prevent damage to them.

**CAUTION:** Cable rings should only be used to reduce strain on cables and not be used for any other purpose.

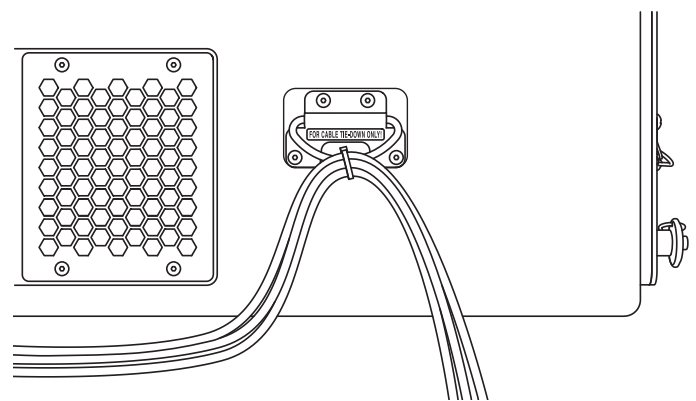

Figure 14. Cables Tied Off to Cable Ring

## 2100-LFC RIGGING

The available rigging hardware, accessories, and 2100-LFC loudspeakers are listed in Table 1.

Table 1. 2100-LFC and Related Accessories

Model	Weight	Features	Required Quick-Release Pins	Required Shackles
2100-LFC Loudspeaker (09.328.001.01)	235 lb (106.6 kg)	Includes end-frames and GuideALinks secured with custom quick-release pins (QRP) for connection to other cabinets and rigging accessories.	7/16 x 0.90-inch QRP (black button) with lanyard PN 134.065 qty 8 included	(none required)
MTG-2100 Grid Kit (PN 40.328.400.01)	100 lb (45.4 kg)	At 5:1 safety factor, with a grid angle of zero degrees (no up or down tilt), capable of suspending up to sixteen (16) 2100-LFC.  Suspends up to eleven (11) 2100-LFC as long as the array's center of gravity does not fall beyond the extents of the grid.	7/16 x 1.5-inch QRP (red button) with lanyard PN 134.051 qty 4 included	3/4-inch or 7/8- inch
MCF-2100 Caster Frame Kit (PN 40.328.200.01)	105 lb (68 kg)	Transports up to three 2100-LFC cabinets (no grid) or two 2100-LFC cabinets + MTG-2100 Grid allowing assembly and disassembly arrays in blocks of two or three cabinets.	This accessory is secured with the quick-release pins included with each 2100-LFC cabinet.	(none required)
Pull-Over Cover, 3-High (PN 79.328.111.03)		Protects loudspeakers during transit and storage.		
Pull-Over Cover, 2-High (PN 79.328.111.02)		Protects loudspeakers during transit and storage.		



**NOTE:** The MCF-2100 Caster Frame does not include quick-release pins. This accessory is secured with the quick-release pins included with each 2100-LFC cabinet.



**CAUTION:** Always model each array configuration in Meyer Sound's MAPP System Design and Prediction software to determine if the array configuration is within safety limits (5:1 safety factor). Do not suspend an array when the Safety Limits Analysis in MAPP displays "Configuration has exceeded the rated load capacity."



**CAUTION:** The 2100-LFC QuickFly rigging system includes custom quick-release pins. When assembling a 2100-LFC array, use only quick-release pins acquired from Meyer Sound to secure the connecting hardware (GuideALinks) and rigging accessories.

## MTG-2100 TOP GRID KIT

The MTG-2100 Top Grid Kit provides mechanical connection between hoisting mechanism(s) and 2100-LFC cabinets.

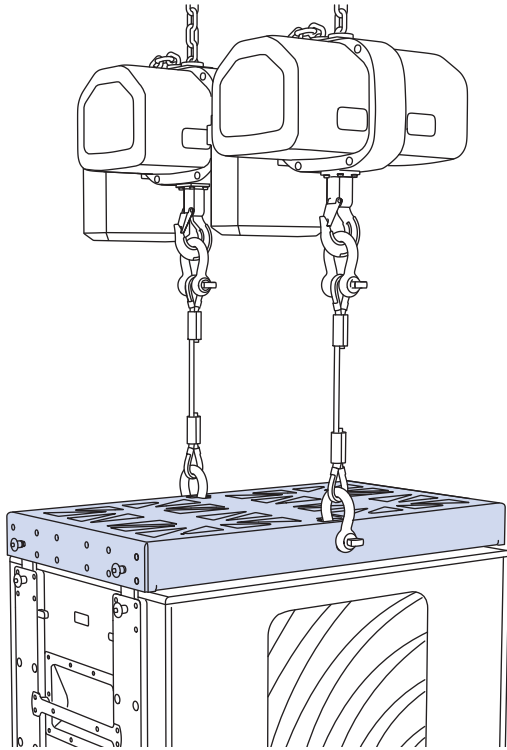

Figure 15. Hoists, MTG-2100 Grid Kit (highlighted), and 2100-LFC Cabinet

### MTG-2100 TOP GRID KIT CONTENTS

The MTG-2100 Grid Kit (PN 40.328.400.01) includes the grid and four quick-release pins.

Table 2. MTG-2100 Top Grid Kit Contents

Image	Qty	Part Number	Description
	1	45.324.400.02	MTG-2100 Grid (only)
	4	134.051	7/16 x 1.5-inch QRP with lanyard (red button)

### MTG-2100 LOAD RATINGS

The MTG-2100 is designed to support only 2100-LFC cabinets. When the grid is used to suspend 2100-LFC, it has the following maximum load ratings:

- Up to sixteen (16) 2100-LFC, no up or down tilt, grid at zero degrees.
- Up to eleven (11) 2100-LFC, any grid angle achievable using the grid alone.

**CAUTION:** Always model each array configuration in Meyer Sound’s MAPP System Design and Prediction software to determine if the array configuration is within safety limits (5:1 safety factor). Do not suspend an array when the Safety Limits Analysis in MAPP displays “Configuration has exceeded the rated load capacity.”

**CAUTION:** The weight of any additional items suspended with the array, e. g., cable, motors, motor chain, must be considered when calculating the weight being suspended.

**CAUTION:** Always use properly rated rigging hardware, e.g., wire rope, shackles, hoists, etc. to suspend any load.

**CAUTION:** Always use the 7/16 x 1.50-inch QRP (lanyard, red button, PN 134.051) included with the MTG-2100 Grid Kit to secure the MTG-2100 Grid to the top 2100-LFC cabinet. These pins are longer than those used for cabinet to cabinet connections.

**TIP:** For transport, the grid can remain on top of a stack of a 2-high 2100-LFC on an MCF-2100 caster frame.

**CAUTION:** Do not transport 3-high stacks of 2100-LFC with the MTG-2100 Grid Kit on top. This exceeds the safety limits for tip-over, which may cause injury.

### MTG-2100 GRID HARDWARE CONNECTIONS

The MTG-2100 Grid does not have a front or rear. It can be turned 180 degrees horizontally without changing its alignment to the cabinets.

When suspended, user-provided 3/4-inch or 7/8-inch shackles connect the hoist(s) to the MTG-2100 Grid. The shackles are connected to the grid, both front and rear. The MTG-2100 must be suspended from both connection points, 24 in (61 cm) apart from each other.

When suspending the MTG-2100 Grid from a single hoist, the minimum bridle leg length is 18 in (46 cm) based on the bridle apex angle being less than 90-degrees.

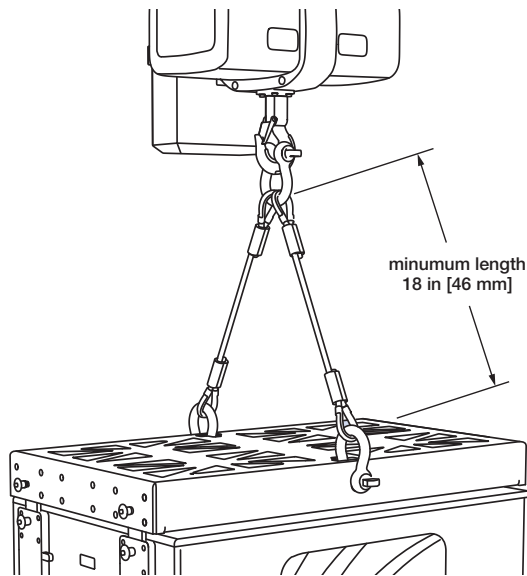

Figure 16. 2100-LFC GuideALinks

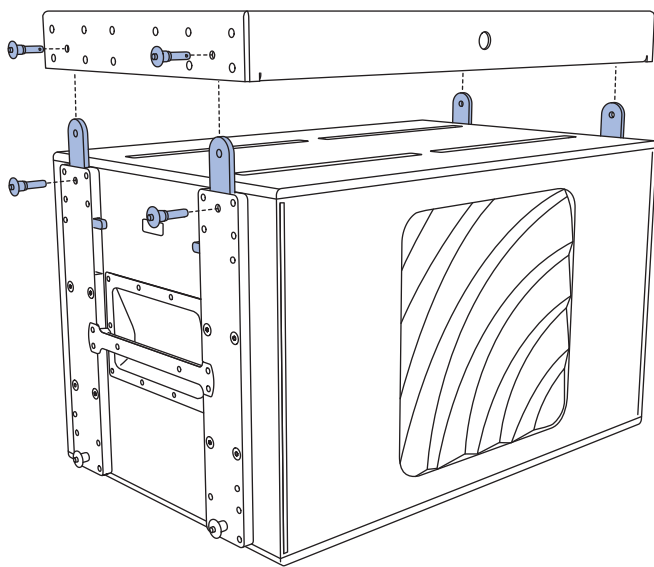

Figure 17. 2100-LFC GuideALinks Extended

The MTG-2100 Grid connects to the GuideALinks of the top 2100-LFC of a flown array with four 7/16 x 1.50-inch QRP (lanyard, red button, PN 134.051) included with the MTG-2100 Grid Kit (Figure 17). These quick-release pins are not interchangeable with any other pins used with a 2100-LFC array.

- ⚠ **CAUTION:** During array assembly, ensure the quick-release pins are fully inserted and locked (not able to be removed without depressing the quick-release pin lock button).
- ⚠ **CAUTION:** The quick-release pins are secured to the 2100-LFC loudspeakers with lanyards. For all pin locations, only use pins whose lanyards are attached to the same cabinet when securing GuideALinks.
- ⚠ **CAUTION:** 2100-LFC GuideALinks must be secured with the included quick-release pins. At no time should the weight of the loudspeaker rest on the GuideALink knobs when the links are fully extended (without the pins inserted). GuideALink knobs are only used to extend and retract the links.

Several attachment points for third-party accessories or equipment racks are available on the top of the grid (Figure 18). For accessories weighing more than 50 lb (23 kg), please contact Technical Support before designing or mounting the accessory.

The locations labeled “B” align with the mounting holes of third-party brackets used to secure laser/inclinometers, e. g., ProSight and ProSight2 mounts. Holes labeled “A” and “C” can accommodate the mounting of custom accessories. For dimensional information, please refer to the CAD (.dwg) drawings available at [meyersound.com](http://meyersound.com).

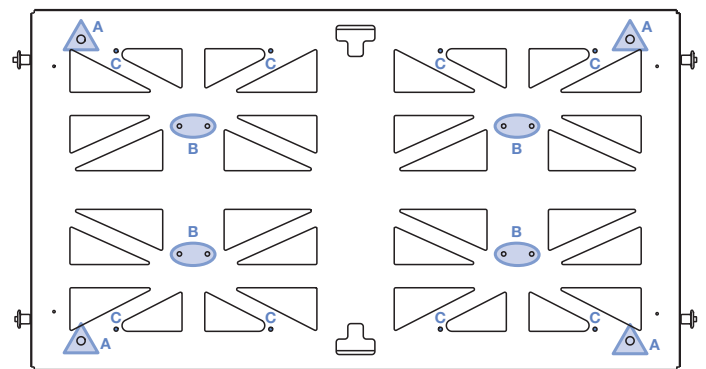

Figure 18. MTG-2100 Grid, Top View

## 2100-LFC GUIDEALINKS

2100-LFC cabinets are equipped with four captive GuideALinks providing connection to the cabinet above (Figure 19) or to the MTG-2100 Grid Kit (Figure 17). Located at the top corners of the cabinet, the GuideALinks extend into the GuideALink sockets of the cabinet above it or into the GuideALink sockets of the MTG-2100 Grid Kit. The splay angle between cabinets is always zero degrees.

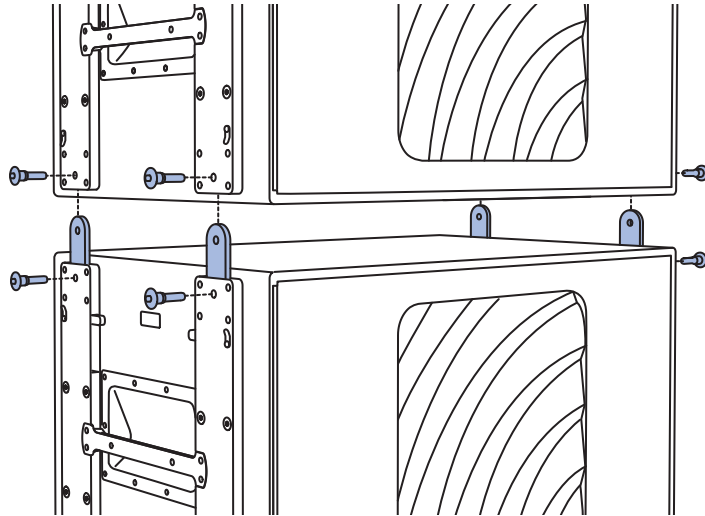

Figure 19. GuideALinks Connect 2100-LFC Cabinets

To raise and lower the GuideALinks, remove the quick-release pin, grasp the GuideALink lever, then raise or lower the GuideALink. The GuideALink position is secured by inserting a quick-release pin when a GuideALink is fully raised or lowered.

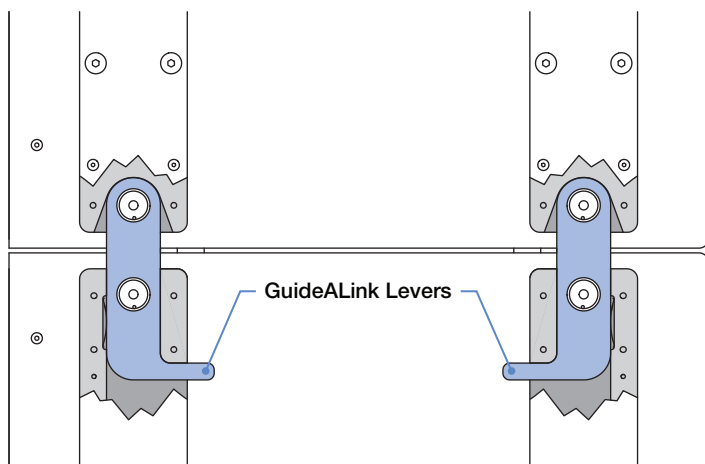

Figure 20. 2100-LFC GuideALink Levers

**CAUTION:** During array assembly, ensure the quick-release pins are fully inserted and locked (not able to be removed without depressing the quick-release pin lock button).

**CAUTION:** 2100-LFC GuideALinks must be secured with the included quick-release pins. At no time should the weight of the loudspeaker rest on the GuideALink Levers when the links are fully extended (without the pins inserted). GuideALink Levers are only used to extend and retract the links.

## MCF-2100 CASTER FRAME

The MCF-2100 Caster Frame safely transports up to three 2100-LFC cabinets or two cabinets and the grid making it easy to assemble and disassemble arrays in groups of two or three cabinets.

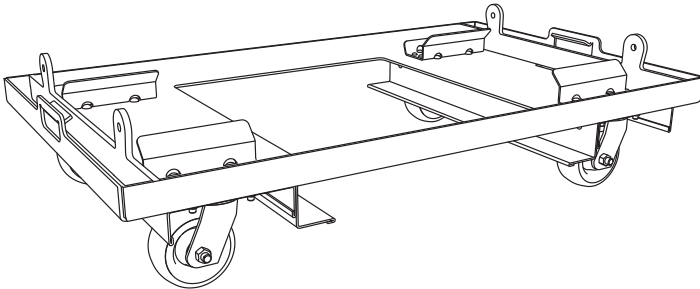

Figure 21. MCF-2100 Caster Frame

The caster frame includes four fixed attachment points (GuideALink tabs) that align with the GuideALink sockets of the bottom 2100-LFC of an array. The caster frame is secured with the quick-release pins included with 2100-LFC cabinets, 7/16 x 0.90-inch QRP (black button, PN 134.065).

**CAUTION:** Do not transport 3-high stacks of 2100-LFC with the MTG-2100 Grid on top. This exceeds the safety limits for tip-over, which may cause injury. Two 2100-LFC cabinets with the grid or three 2100-LFC cabinets (no grid) are the maximum safe configurations of products transported on MCF-2100 caster frames.

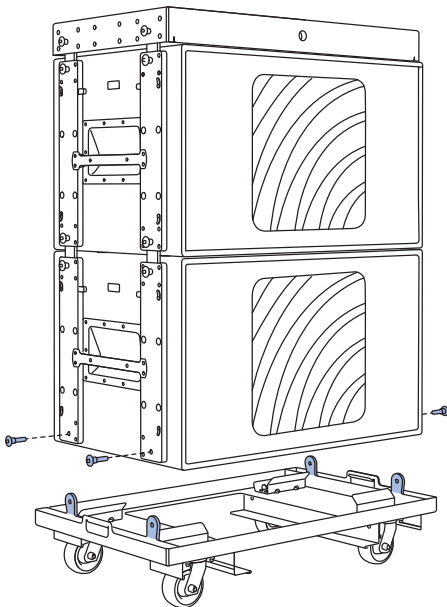

Figure 22. MCF-2100 Caster Frame with 2100-LFC and MTG-2100 Grid

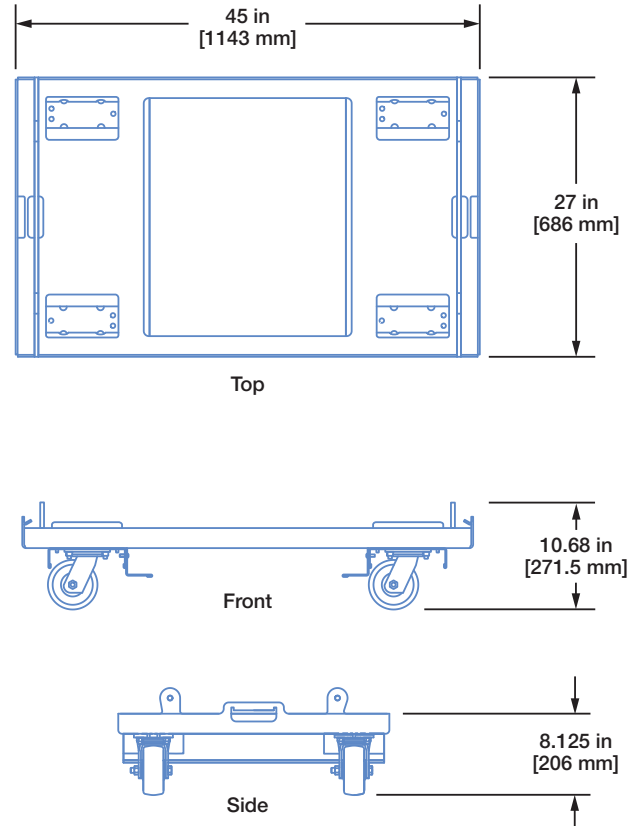

Figure 23. MCF-2100 Caster Frame Dimensions

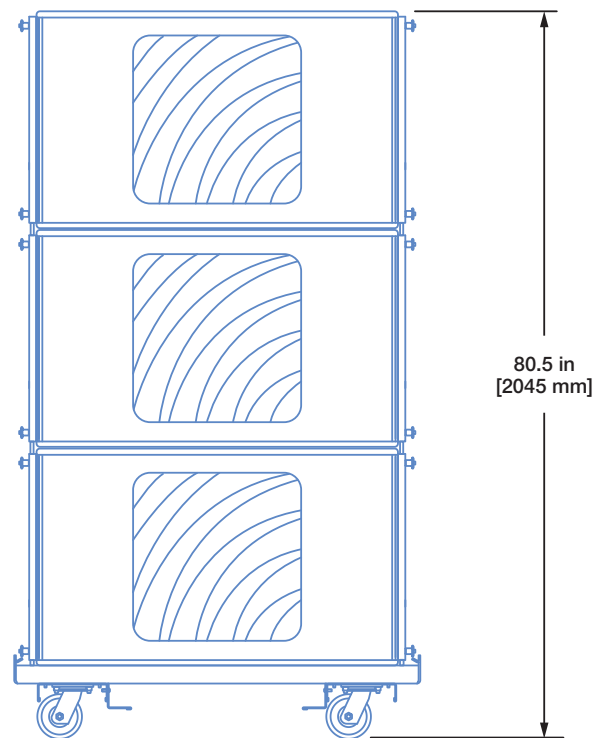

Figure 24. Dimensions of Three 2100-LFC Cabinets on MCF-2100 Caster Frame



**TIP:** Durable, 2-high and 3-high nylon covers are available to ensure the 2100-LFC cabinets are protected during transport.

The caster frame includes forklift guides between the wheels to prevent damage to them. If desired, the forklift guides can be removed without affecting the structural integrity. Remove the three bolts securing each of the guides.

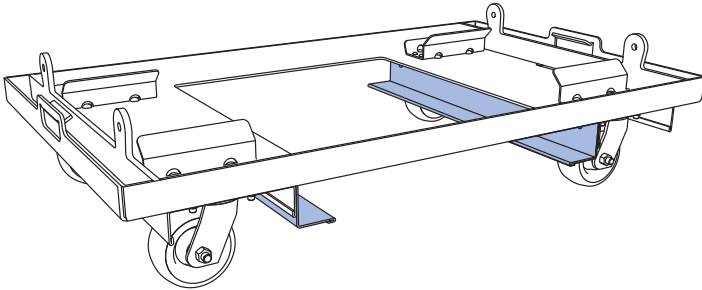

Figure 25. MCF-2100 Caster Frame, Forklift Guides Installed

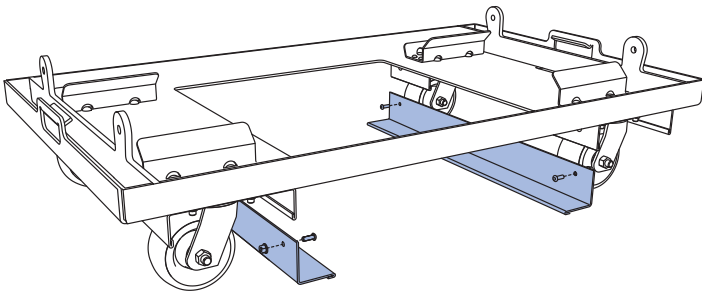

Figure 26. MCF-2100 Caster Frame, Forklift Guides Detached

## SAFETY GUIDELINES FOR THE MCF-2100 CASTER FRAME

- While the MCF-2100 Caster Frame supports up to three cabinets, use extreme caution when moving the caster frame and cabinets to avoid tipping.
- When rolling a caster frame and cabinets, slow down when the surface is uneven, e.g., cracks in concrete floors, cable ramps, transitions in floor coverings, etc.
- Do not move stacks in the front-to-rear direction of the 2100-LFC cabinets (the long side) as the risk of injury increases. Always move stacks sideways to avoid tipping.
- When moving the caster frame with 2100-LFC cabinets, always use the handles of the cabinets and push or pull from one of the ends.
- To avoid tipping, transport stacks with all the GuideALinks connected to adjacent cabinets.
- The caster frames must be removed before the array is flown.

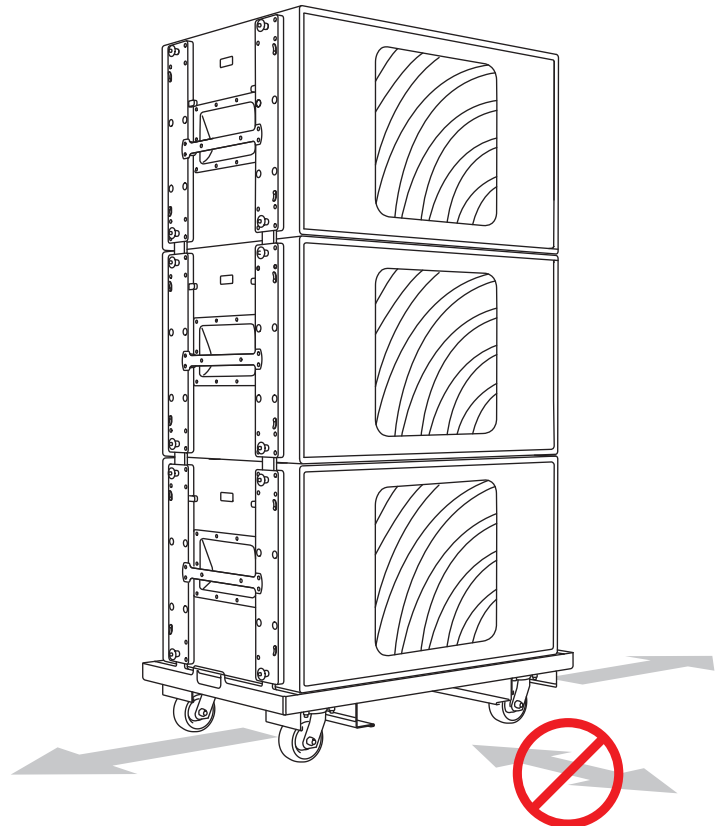

Figure 27. MCF-2100 Caster Frame with 2100-LFC Stack



## ASSEMBLING ARRAYS

BEFORE ASSEMBLING AN ARRAY, REVIEW THE RIGGING SAFETY STATEMENT ON [PAGE 3](#) OF THIS DOCUMENT.

### USER-PROVIDED EQUIPMENT

Depending on the application and the needs, the following equipment may be needed considered:

- hoists, motorized
- rated rigging hardware, e. g., shackles, wire rope, pear rings, etc.
- tape measure or laser distance measurement device
- load cells - used to measure rigging loads



**NOTE:** When using inverted chain motors (motor down), a short length of wire rope or deck chain added between the MTG-2100 Grid Kit and the hook on the motor allows proper collection of the take-up chain in the chain bag without spilling.

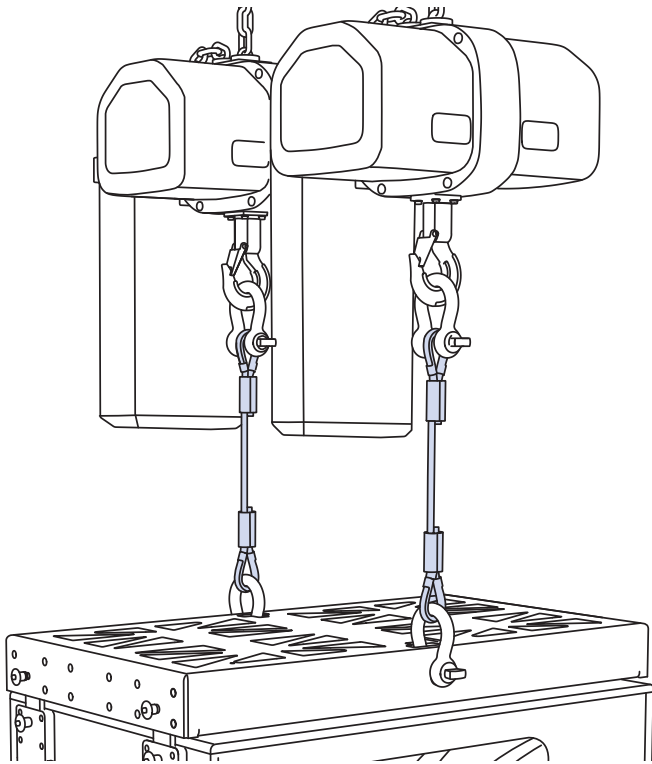

Figure 28. Chain Motors with Wire Rope Elevating Hoists Above MTG-2100 Grid Kit.

### ARRAY ASSEMBLY PREPARATION

Use acoustic predictions provided by Meyer Sound's MAPP System Design and Prediction software to determine the optimum array position, number of 2100-LFC loudspeakers required, and the Grid Kit height and angle.

From the MAPP design, document the following array information:

- Trim height
- Direction cabinet faces (forward/rearward) for gradient arrays
- Total array weight
- Drive line assignments, Galileo GALAXY output channels



**NOTE:** In some regions, regulations require dead-hanging all suspended loads, bypassing the loading of all movable hoists. A dead hang uses a wire rope or chain to carry the suspended load, removing the entire load from the hoisting mechanism(s) used to raise and lower the array. Ensure the proper rigging equipment is available when needed.

### Structural Attachment Point Locations

Install and locate the rigging points above the intended location of the array. The spacing between the rigging attachment points of the MTG-2100 is 24 in (61 cm), along the center line of the grid.

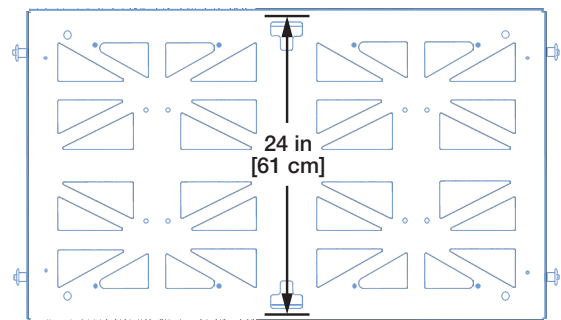



Figure 29. MTG-2100 Grid Rigging Attachment Points

## ARRAY ASSEMBLY STEPS

Because the 2100-LFC cabinets are horizontally symmetrical, when the steps below give instructions related to one side of a cabinet, always duplicate the action on the other side of the cabinet. The duplicate instruction for the other side of the cabinet is not included.

These instructions assume the 2100-LFC cabinets are already stacked on caster frames, ready for temporary installation, e. g., touring or one-off events, and that the MTG-2100 Grid is not already connected to the top 2100-LFC cabinet. For installations, it is likely that individual cabinets will be located on the working surfaces below the rigging points and added one at a time to the array. If there are questions, please contact Technical Support by visiting [meyersound.com/contact](http://meyersound.com/contact).

### 1. Ready the hoisting mechanism(s).

 **CAUTION:** Discover and follow all safety regulations and operational rules regarding movement of suspended loads for the region, location, and venue where the system will be deployed.

### 2. Securely mount any accessories to the MTG-2100 Grid Kit, e. g., lasers, inclinometers, tape measure, etc.

### 3. Prepare 2100-LFC cabinets.

- Remove protective covers from stacks of 2100-LFC cabinets and arrange the stacks in the order they will be added to the array.

 **NOTE:** Leave the GuideALinks of the top cabinet of each stack retracted.

### 4. Connect the MTG-2100 Grid to hoist(s).

- Locate the MTG-2100 Grid on the floor or a cable trunk directly below the hoist(s).
- Connect 3/4-inch or 7/8-inch shackles to the grid.
- Connect the hoist(s) to the shackles.

### 5. Connect the MTG-2100 to the first stack of 2100-LFC cabinets (Figure 30).

- Raise the MTG-2100 Grid until it is higher than the 2100-LFC cabinets being connected.
- Move the first stack of 2100-LFC cabinets under the grid.
- Lower the MTG-2100 Grid until it is 1 to 2 inches (2.5 cm to 5cm) above the top 2100-LFC cabinet, close enough to allow the front GuideALinks to extend into the GuideALink sockets of the grid.

 **CAUTION:** Do not attempt to “land” the MTG-2100 Grid on a 2100-LFC cabinet with the GuideALinks extended. Collision of the GuideALinks and the GuideALink sockets will cause excessive wear over time.

- Remove the quick-release pins that are attached to the MTG-2100 Grid and let them hang from their lanyards.
- For the top 2100-LFC, remove the quick-release pin of the front GuideALink, raise the GuideALink with the GuideALink lever, then re-insert the previously removed quick-release pin. Repeat for the rear GuideALink.
  - The GuideALinks should extend into the GuideALink sockets of the grid, but won't be entirely seated.
- Lower the grid until it rests on the extended GuideALinks.
- Insert the four 7/16 x 1.50-inch QRP (red button, PN 134.051) quick-release pins attached to the grid to secure the GuideALinks of the cabinet to the grid.

 **CAUTION:** Make sure the quick-release pins are fully inserted and locked, unable to be removed without depressing the button of the quick-release pin.

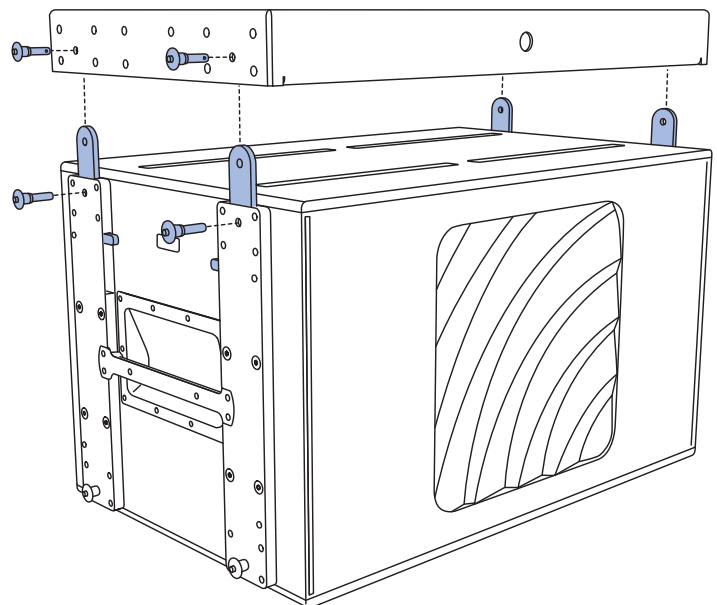



Figure 30. 2100-LFC GuideALinks Extended

6. Connect the strain relief (cable pick) for the cable going to the ground to a pear ring and/or shackle and attach it the rear hoist. If a single hoist is used, consider attaching the strain relief around the central structural member of the grid.
7. Connect the power and signal cables to the cabinets ready to be hoisted.
8. Visually inspect the assembly before hoisting, make sure:
  - The rigging hardware is properly oriented and won't "jam" or "foul," especially the shackles.
  - Cables are properly routed and will not be strained, pinched, or damaged when the array is raised.
  - Each cabinet is linked to the cabinet above it, verifying that each of the four GuideALinks of each cabinet are extended and pinned in place with 7/16 x 0.90-inch QRP (black button, PN 134.065) quick-release pins attached by lanyard to each cabinet.
9. Remove the MCF-2100 Caster Frame
  - Lift the array with the hoists until none of the caster frame wheels touch the working surface.
  - Remove the MCF-2100 Caster Frame

 **CAUTION:** Do not lift the caster frame by the handles while it is being removed or attached to a cabinet. This creates a pinch point for hands. Only lift the caster frames by the handles when the caster frame is not connected to a cabinet.

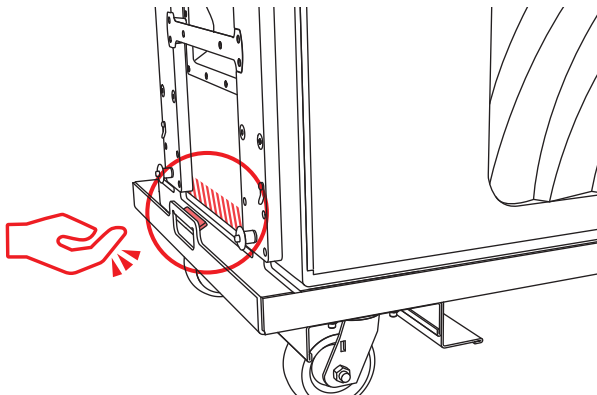



Figure 31. Caster Frame Handle Pinch Point

- First, remove both front pins that secure the caster frame while supporting the underside of the caster frame by hand.
- Lower the front wheels to the floor.
- Next, remove both rear pins that secure the caster frame while supporting the underside of the caster frame by hand.

- Lower the rear wheels of the caster frame to the floor.
  - Unless it is the last stack to be flown, leave the quick-release pins dangling from their lanyards.
10. Prepare to connect another stack of loudspeakers.
    - Ensure the connected cabling has enough slack to not be strained, pinched or damaged as the array is raised.
    - Raise the array, loading the hoists equally, until the cabinets are about 6 inches (15 cm) higher than the next stack of cabinets to be attached.
    - Move the stacked cabinets under the suspended cabinets, aligning the corners.
    - Make sure the GuideALinks of the top stacked cabinet are retracted.
-  **CAUTION:** Do not attempt to "land" the suspended cabinets on a stacked cabinet with the GuideALinks extended. Collision of the GuideALinks and the GuideALink sockets will cause excessive wear over time. Collision of an extended GuideALink and the wooden bottom of a cabinet above it can puncture or damage the cabinet.
- Lower the suspended cabinets within 1 to 2 inches (2.5 to 5 cm) above the top of the cabinet to be connected.

11. Connect the next stack of loudspeakers.
  - For the cabinet to be connected, remove the quick-release pins and extend the front and rear GuideALinks into the link sockets of the suspended cabinet. Reinsert the quick-release pins in the same holes to secure the GuideALinks in the raised position with the 7/16 x 0.90-inch QRP (black button, PN 134.065) attached by lanyards to the cabinet.
  - Lower the suspended cabinets until their weight is supported by the stacked cabinets.
    - The raised GuideALinks keep the flown cabinets aligned to the stacked cabinets.
  - Secure the front and rear GuideALinks to the suspended cabinets by reinserting the 7/16 x 0.90-inch QRP (black button, PN 134.065) quick-release pins attached to the bottom, suspended cabinet.

 **CAUTION:** Make sure the quick-release pins are fully inserted and locked, unable to be removed without depressing the button of the quick-release pin.

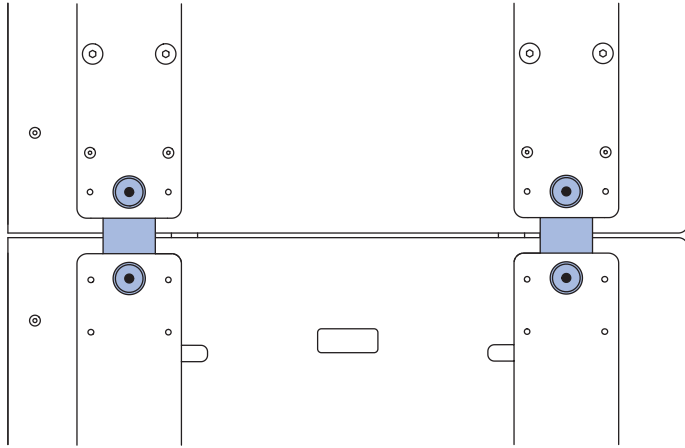



Figure 32. GuideALinks Extended and Secured to the Cabinet Above with Quick-Release Pins.

-  **NOTE:** The lanyards of the quick-release pins may be damaged if quick-release pins are inserted in an adjacent cabinet.

Repeat Steps 7-11 for each additional stack of cabinets to be added to the array.

### Before Raising the Array

- Make sure all the grid-to-top cabinet GuideALinks are secured with the 7/16 x 1.50-inch QRP (red button, PN 134.051).
- Make sure all cabinet-to-cabinet GuideALinks are secured with the 7/16 x 0.90-inch QRP (black button, PN 134.065), included.
- Make sure the connected rigging hardware is properly aligned, especially the shackles.
- Make sure the connected cabling has enough slack to not be strained and won't be pinched or snag as the array is lifted.

-  **NOTE:** At this assembly step, users typically terminate the power, signal, and network cabling and verify proper signal patching so any issues can be addressed before the array raised.

12. Trim the array in its final position.

-  **NOTE:** The Reference Point, front or rear, is selected in MAPP. The front and rear Reference Points are the front and rear shackle mounting points on the MTG-2100 Grid.

- Verify and adjust as needed: height and grid angle until the design parameters are achieved.

-  **CAUTION:** Do not tip the array forward or backward while raising the array. All motors should carry the same amount of weight.

### STACKING CASTER FRAMES

The MCF-2100 Caster Frames can be stacked on top of one another for storage. When stacking, tip the caster frame enough that all the wheels rotate the same direction, then lower the caster frame onto another.

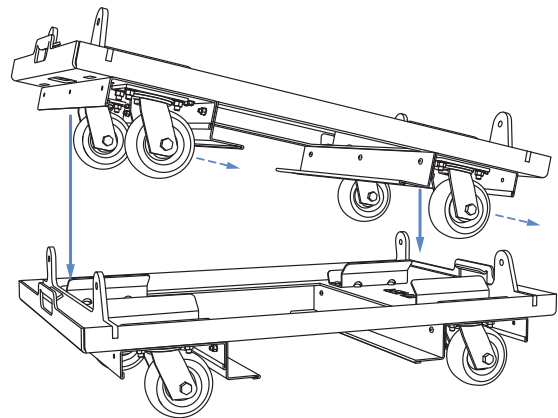

Figure 33. MCF-2100 Caster Frame Stacking, Tip to Rotate Casters, Lower to Stack

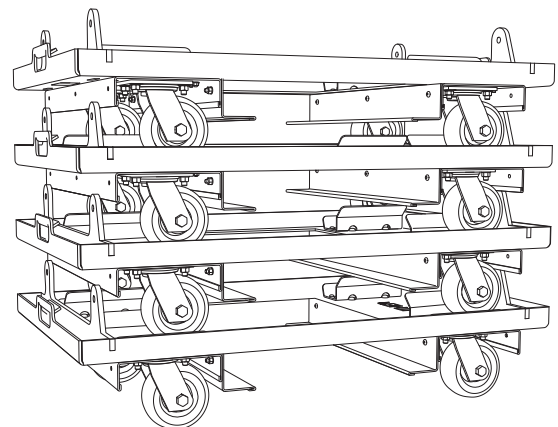

Figure 34. MCF-2100 Caster Frames Stacked

## **OUTDOOR USE**

When deployed outdoors, it is common to secure the bottom of an array to structural points to prevent movement due to light wind.

It is typical to “land” arrays when there are high winds or when staff is not on site, e. g., overnight at a festival. When landing an array, keep the bottom of the bottom cabinet of the array parallel to the working surface. To prevent the cabinets sitting in water, add spacing material (e. g., wooden blocks)

## DISASSEMBLING ARRAYS

### ARRAY DISASSEMBLY PREPARATION

- De-energize the electrical system providing power to the loudspeakers.
- Disconnect cabling connected to equipment on the ground.
- Disconnect any rigging hardware used to secure the horizontal aim of the array.
- If the array is dead hung (required in some regions), raise the hoists so they take weight and remove the rigging hardware associated with the dead hang.

### ARRAY DISASSEMBLY STEPS

Because the 2100-LFC cabinets are horizontally symmetrical, when the steps below give instructions related to one side of a cabinet, always duplicate the action on the other side of the cabinet. The duplicate instruction for the other side of the cabinet is not included.

Before lowering the array, make sure the attached cabling has enough slack and that the area around and under the array is clear of obstructions.

**CAUTION:** Discover and follow all safety regulations and operational rules regarding movement of suspended loads for the region, location, and venue where the system will be deployed.

1. Equalize the motor load (grid angle zero degrees), then lower the array until the bottom cabinet is 1 to 2 inches (2.5 to 5 cm) above the height of the caster frame GuideALink tabs, and move a caster frame under the cabinets.

2. Connect the caster frame to the bottom of the array.

**CAUTION:** Do not lift the caster frame by the handles while it is being removed or attached to a cabinet - a hand pinch point is created. Only lift the caster frames by the handles when the caster frame is not connected to a cabinet.

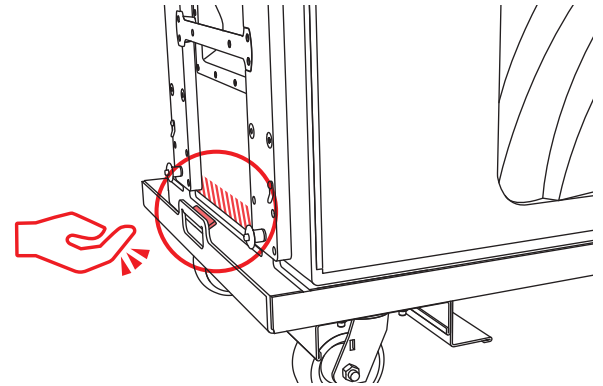

Figure 35. Caster Frame Handle Pinch Point

**CAUTION:** Do not attempt to “land” the MTG-2100 Grid on a caster frame. Collision of the caster frame tabs and the GuideALink sockets will cause excessive wear over time.

- Remove all four of the quick-release pins from the bottom GuideALink sockets of the bottom cabinet.
  - From the underside of the caster frame, lift the front or rear, seating the GuideALink tabs of the caster frame in the rear GuideALink sockets of the cabinet.
  - Insert the previously removed quick-release pins to secure the caster frame.
  - Lift the other end of the caster frame, secure with the previously removed quick-release pins.
3. Lower the array until the caster frame wheels contact the working surface.
  4. For the cabinets to be removed, disconnect all cabling and release any strain-reliefs.
  5. For the bottom cabinet to remain suspended, remove the lower, front and rear quick-release pins.

**NOTE:** Small adjustments of the hoists may be necessary to relieve tension or compression of the GuideALinks and quick-release pins.

7. For the top cabinet to be removed, remove the upper, front and rear quick-release pins - GuideALinks will retract
8. Reinsert the previously removed quick-release pins.

9. Prepare the stack to be transported.

**!** **CAUTION:** When 2100-LFC cabinets are stacked on caster frames, the front and rear GuideALinks of each cabinet should be extended and secured in place with quick-release pins connecting each cabinet of the stack to one another.

**!** Do not transport the cabinets with the GuideALinks of the top cabinet extended to prevent damage while transporting.

- Move the disconnected cabinets away from the work area to a safe location.
- Open the flap of the 2 or 3-high cover and slide over the top of the stacked cabinets.

Repeat Steps 1-9 for additional stacks of cabinets.

### Transporting MTG-2100 on Cabinets

When transporting a MTG-2100 Grid on a stack of one or two cabinets, use the front and rear GuideALinks to secure the grid to the top cabinet. This is the same configuration of the GuideALinks as when the array is suspended.

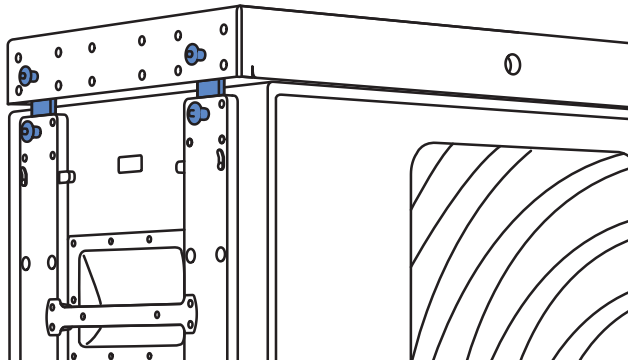

Figure 36. GuideALinks Extended and Secured with Quick-Release Pins

**!** **CAUTION:** Do not transport 3-high stacks of 2100-LFC with the MTG-2100 Grid on top. This exceeds the safety limits for tip-over, which may cause injury.

## COMPLIANCE

thinking sound



Meyer Sound Laboratories Inc.  
2832 San Pablo Ave.  
Berkeley, CA 94702-2204  
USA

Phone +1-510-486-1166  
Fax +1-510-486-8356  
info@meyersound.com  
www.meyersound.com

### FCC DECLARATION OF CONFORMITY

**Trade Name:** Meyer Sound Laboratories

**Product Name:** Powered Speaker

**Product Model Number:** 2100-LFC

These devices comply with Part 15 of the FCC Rules  
Operation is subject to the following conditions:  
The devices may not cause harmful interference, and  
The devices must accept any interference received, including  
interference that may cause undesired operation

#### RESPONSIBLE PARTY

**Responsible Party's Name:** Meyer Sound Laboratories  
**Address:** 2832 San Pablo Ave, Berkeley CA. 94702, USA  
**Telephone:** 510-486-1166

**Signature:**

A handwritten signature in blue ink, appearing to read "John McMahon", written over a horizontal line.

**Date:** June 21, 2023  
**Printed Name and Title:** John McMahon, Senior Vice President

#### FCC Class A Notice

**Note:** This equipment has been tested and found to comply with the limits for a Class A digital device, pursuant to part 15 of the FCC Rules. These limits are designed to provide reasonable protection against harmful interference when the equipment is operated in a commercial environment. This equipment generates, uses, and can radiate radio frequency energy and, if not installed and used in accordance with the instruction manual, may cause harmful interference to radio communications. Operation of this equipment in a residential area is likely to cause harmful interference in which case the user will be required to correct the interference at his own expense.

Modifications not expressly approved by the manufacturer could void the user's authority to operate the equipment under FCC rules.

**ICES-003 Class A Notice - Avis NMB-003, Classe A**  
This Class A digital apparatus complies with Canadian ICES-003.  
Cet appareil numérique de la classe A est conforme à la norme NMB-003 du Canada.

**Warning:** This equipment is compliant with Class A of CISPR 32.  
In a residential environment this equipment may cause radio interference.



## SPECIFICATIONS

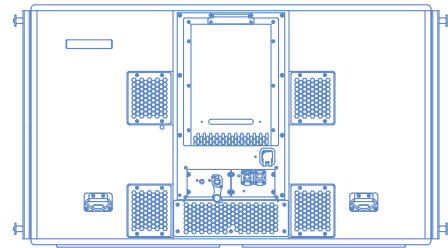
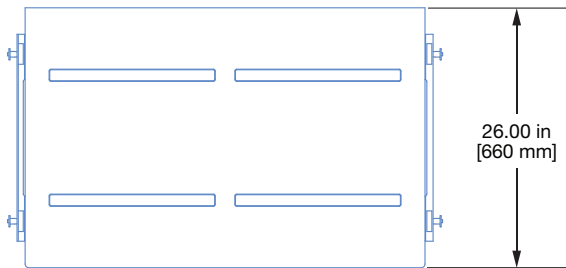
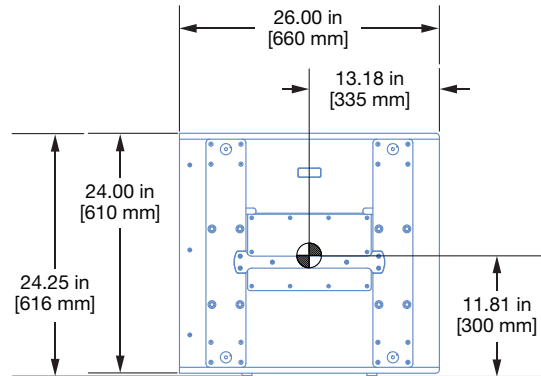
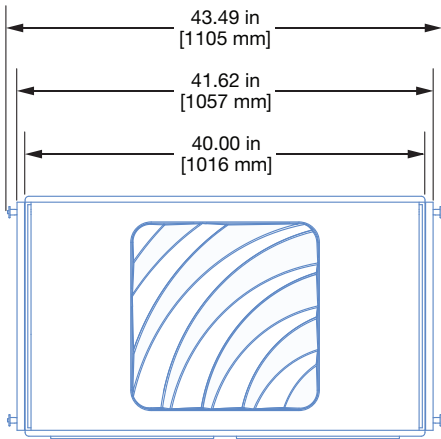

ACOUSTICAL	
Operating Frequency Range	30 Hz – 125 Hz
AES75 Maximum Linear Sound Levels	139.1 dBZpk, 129.2 dBZ, with an RMS input level of +6.0 dBV for analog, -17.8 dBFS for digital
<ul style="list-style-type: none"> <li>Linear Sound Levels are measured in half-space at 4 m with a Class 1 sound level meter in accordance with IEC 61672 and ANSI S1.4. Values are scaled to 1 m distance from the loudspeaker while the loudspeaker is reproducing the AES75 test signal for at least one hour when the ambient temperature is 45 C° (113 F°).</li> <li>Loudspeaker system predictions for coverage and SPL are available in Meyer Sound's MAPP System Design Tool.</li> </ul>	
COVERAGE	
	360° (single unit)
PHYSICAL	
Weight	235 lbs. (106.6 kg)
Enclosure	Premium multi-ply birch, slightly textured black finish
Protective Grille	Powder-coated, stamped steel
Rigging	End frames with captive GuideALinks secured with 0.4375 in x 0.090 in quick-release pins
IEC Ingress Protection Rating (IP Rating)	IP55, when connected to cables terminated with Neutrik TOP connectors
POWER CONSUMPTION	
Max Long-Term Continuous Power (>10 sec)	1200 W
Burst Power (<1 sec)	2400 W
AC POWER	
Connector	Neutrik powerCON TRUE1 TOP (True Outdoor Protection)
Operating Voltage Range	200 – 240 V AC, 50 or 60 Hz

<b>ANALOG AUDIO INPUT</b> (standard equipped)	
Connector	Neutrik XLR 3-pin TOP (True Outdoor Protection) female input with male loop output
Input Level	Source must be capable of producing +26 dBu into 600 $\Omega$ to produce the maximum peak SPL over the operating bandwidth of the loudspeaker
<b>DIGITAL AUDIO INPUT</b> (standard equipped)	
Connector	Neutrik etherCON TOP (True Outdoor Protection)
Digital Format	AVB, Milan Certified
<b>MONITORING</b>	
Telemetry	Loudspeaker telemetry transmitted via the Ethernet port, displayed in software
<b>TRANSDUCERS</b>	
Low Frequency	One 21-inch long-excursion cone driver; 4 $\Omega$ nominal impedance

Specification Data Reference: 2100-LFC Datasheet, 04.328.004.02 B5 2308